

Sales document

Technical description

Product series K08 Delta

N117/3600, N117/3675, N117/3780, N117/3000 controlled



K0801_074760_EN

Revision 13 / 2025-01-06

– Translation of the original document (K0801_074760_DE, rev. 13) –
This is a translation from German. In case of doubt, the German text shall prevail.

Document is published in electronic form.

Signed original at Nordex Energy SE & Co.KG, Engineering department.

This document was created by Nordex Energy SE & Co. KG and/or an affiliated company as defined in section 15 et seq. of the German Stock Corporation Act (AktG).

This document, including any presentation of its contents in whole or in parts, is the intellectual property of Nordex Energy SE & Co. KG and/or affiliated companies within the meaning of section 15 et seq. of the German Stock Corporation Act (AktG). The information contained in this document is confidential and must never (not even in extracts) be disclosed to third parties without the prior written approval of Nordex Energy SE & Co. KG.

All rights reserved.

Any disclosure, duplication, translation or other use of this document or parts thereof, regardless if in printed, handwritten, electronic or other form, without the explicit approval of Nordex Energy SE & Co. KG is prohibited.

© 2025 by Nordex Energy SE & Co. KG.

Contact

For questions relating to this documentation please contact:

Nordex Energy SE & Co. KG

Langenhorner Chaussee 600

22419 Hamburg

Germany

Tel: +49 (0)40 300 30-1000

Fax: +49 (0)40 300 30-1101

<http://www.nordex-online.com>

info@nordex-online.com

Turbine generation	Product series	Product
Delta	K08 Delta	N117/3600 N117/3675 N117/3780 N117/3000 controlled

1. Structure

The Nordex N117/3600 wind turbine (WT) is a speed-variable wind turbine with a rotor diameter of 116.8 m and a nominal power of 3600 kW. It is offered in versions for 50 and 60 Hz, as N117/3675 and N117/3780 with extended rated power and as N117/3000 controlled, reduced to 3000 kW rated power. The wind turbine is designed for class S in accordance with IEC 61400-1 or for class 3 in accordance with DIBt.

The wind turbine consists of the following main components:

- Rotor, with rotor hub, three rotor blades and the pitch system
- Nacelle with drive train, generator and yaw system
- Tubular tower with foundation
- Medium-voltage transformer (MV transformer) and medium-voltage switchgear (MV switchgear)

1.1 Tower

The Nordex N117/3600, N117/3675, N117/3780 or N117/3000 controlled is mounted on tubular steel towers with different hub heights. The cylindrical steel tower has a conical head section and consists of 3 to 6 sections. Corrosion protection is guaranteed by a coating system of the surface according to ISO 12944. A service lift, the vertical ladder with fall arrest system as well as resting and working platforms inside the tower allow for a weather-protected ascent to the nacelle.

The size and design of the foundation depend on the ground conditions at the intended site. The tubular steel tower is bolted to the anchor cage embedded in the foundation.

Switch cabinets are integrated in the tower base, which contain important components of the electronic controls, the turbine PC, frequency converter, low-voltage main switch, fuses, the transformer for auxiliary power in the tower base and outputs to the transformer and to the generator. The frequency converter is equipped with a water cooling system. The water heated in the frequency converter is cooled in a water/air heat exchanger. It is located on the outer tower wall.

The MV transformer and MV switchgear may be located in a separate transformer substation near the wind turbine. For the transformer in the tower (TIT) variant, the MV transformer and MV switchgear can also be located in the tower base.

In this case, the components in the tower base of the tubular steel tower are arranged on three different levels:

- The MV transformer on the foundation
- The MV switchgear on the first tower platform
- The switch cabinet with frequency converter on the second tower platform

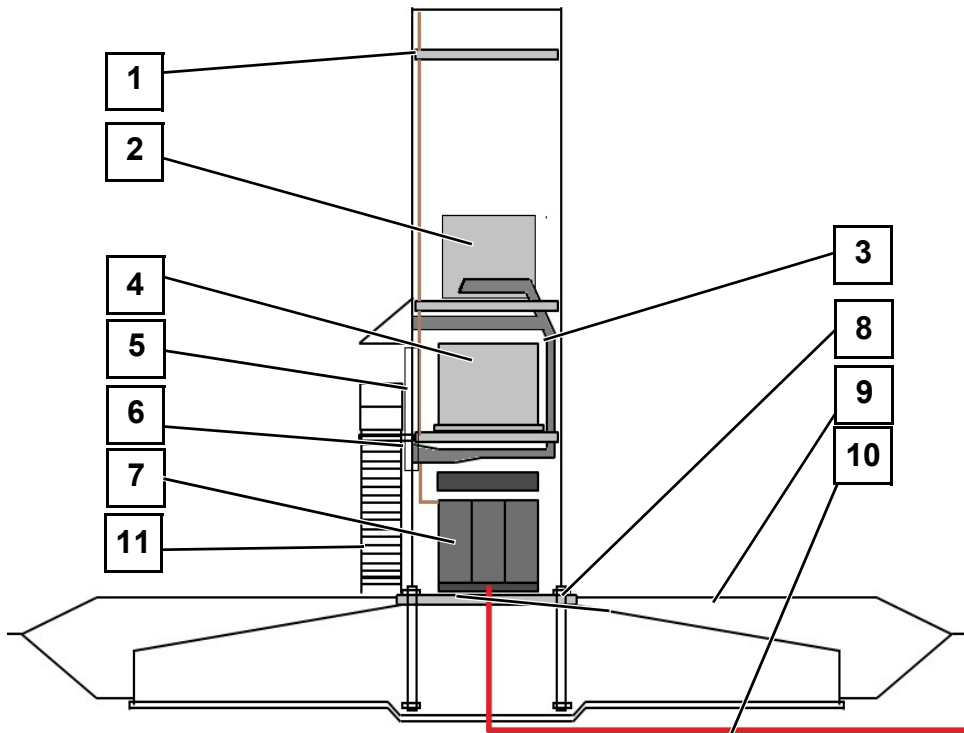

Fig. 1 Section through the tower base, variant with transformer inside tower (TIT)

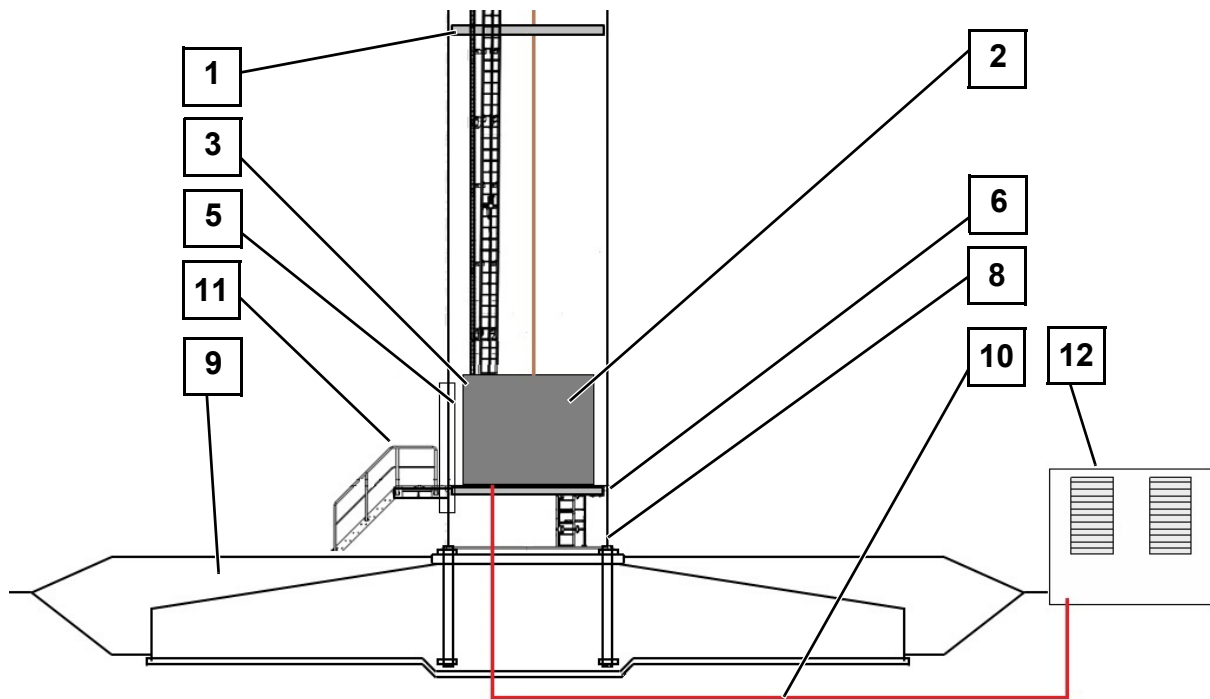

Fig. 2 Section through the tower base, variant with transformer outside tower (TAT)

- | | | | | | |
|----|--------------------------|----|--------------------------|----|--|
| 1 | Flange tower platform | 2 | Switch cabinet/converter | 3 | Ventilation/cooling |
| 4 | MV switchgear (TIT) | 5 | Tower door | 6 | First tower platform |
| 7 | Transformer (TIT) | 8 | Anchor bolts | 9 | Soil backfill |
| 10 | Power cables in conduits | 11 | Tower stairs | 12 | Transformer substation with switchgear (TAT) |

1.2 Rotor

The rotor consists of the rotor hub with three slewing bearings and three pitch drives for blade adjustment as well as three rotor blades.

The **rotor hub** consists of the base element, support structure and spinner. The base element consists of a stiff cast structure, on which the pitch bearings and the rotor blades are assembled. The rotor hub is covered with the spinner which enables the direct access from the nacelle into the rotor hub.

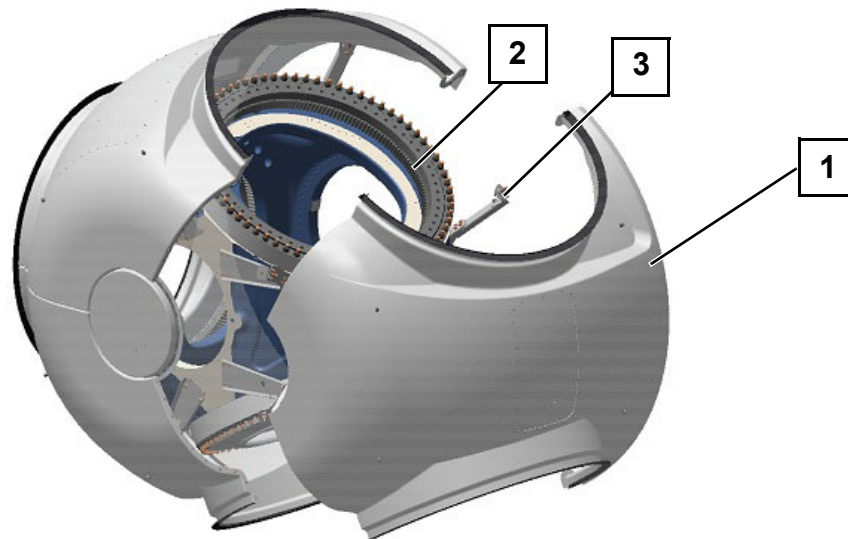

Fig. 3 Rotor hub and spinner of Nordex Delta generation wind turbines

1 Spinner segment 2 Rotor hub 3 Spinner support structure

The **rotor blades** are made of high-quality glass-fiber reinforced plastics and carbon-fiber reinforced plastic. The rotor blade is statically and dynamically tested in accordance with the guidelines IEC 61400-23 and GL IV-1 (2010). If requested by the customer, the rotor blades can be equipped with serrations, which optimize the sound power level.

The **pitch system** serves to adjust the pitch angle of the rotor blades set by the control system. For each individual rotor blade the pitch system comprises an electromechanical drive with rotary current motor, planetary gear and drive pinion, as well as a control unit with frequency converter and emergency power supply. Power supply and signal transfer are realized through a slip ring in the nacelle.

1.3 Nacelle

The nacelle contains essential mechanical and electrical components of the wind turbine. The nacelle can be pivoted on the tower.

The **rotor shaft** is supported in the rotor bearing inside the nacelle. A rotor lock is integrated in the rotor bearing, with which the rotor can be reliably locked in place mechanically.

The **gearbox** increases the rotor speed until it reaches the speed required for the generator.

The bearings and gearings are continuously lubricated with oil. A 2-stage pump enables the oil circulation. A combination filter element with coarse, fine and ultrafine filter retains solid particles. The control system monitors the contamination of the filter element.

The gear oil used for lubrication also cools the gearbox. The temperatures of the gearbox bearings and the oil are continuously monitored. If the optimum operating temperature is not yet reached, a thermal bypass directs the gear oil directly back to the gearbox. If the operating temperature of the gear oil is exceeded it is cooled down.

The gearbox cooling is realized with an oil/water cooler that is installed directly at the gearbox. The heated cooling water is cooled together with the cooling water of the generator in a passive cooler on the roof of the nacelle.

The **generator** is a 6-pole doubly-fed induction machine. An air/water heat exchanger is mounted on the generator. The cooling water is re-cooled together with the cooling water of the gearbox heat exchanger in a passive cooler on the roof of the nacelle.

The mechanical **rotor brake** supports the aerodynamic braking effect of the rotor blades as soon as the rotor speed falls below a defined value and finally stops the rotor. The aerodynamic braking effect of the rotor is achieved by adjusting the rotor blades perpendicular to the rotation direction. The rotor brake consists of a brake caliper, which acts on the brake disk assembled behind the gearbox.

The **yaw drives** optimally rotate the nacelle into the wind. The four yaw drives are located on the machine frame in the nacelle. A yaw drive consists of an electric motor, multi-stage planetary gear, and a drive pinion. The drive pinions mesh with the external teeth of the yaw bearing.

Being positioned properly, the nacelle is locked by means of a hydraulic and an electric brake system. It consists of several brake calipers which are fastened to the machine frame and act on a brake disk. In addition, the electric motors of the yaw drives are equipped with an electrically actuated holding brake.

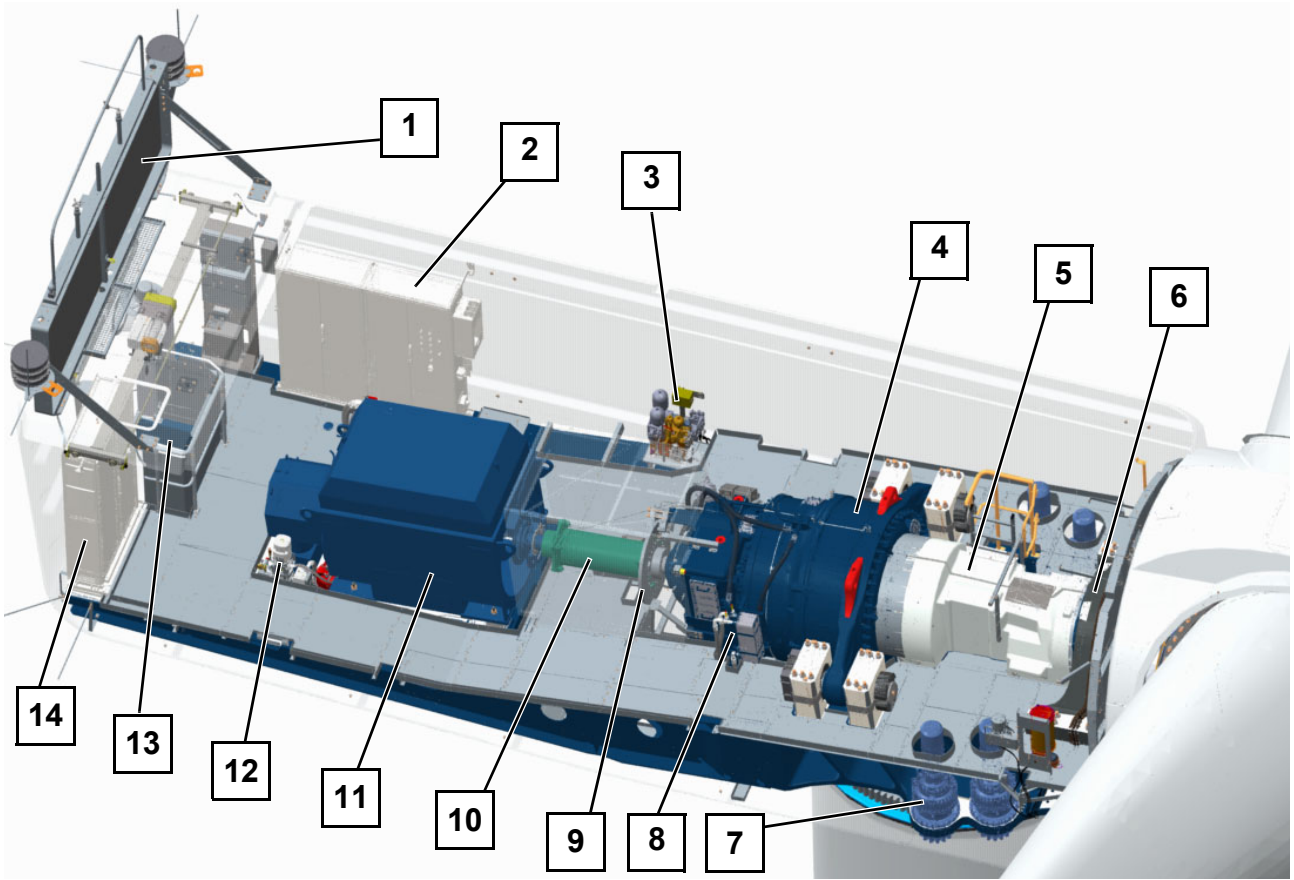

Fig. 4 Nacelle layout drawing

- | | | | |
|----|--------------------------------|----|-----------------|
| 1 | Heat exchanger | 2 | Top box |
| 3 | Hydraulic unit | 4 | Gearbox |
| 5 | Rotor shaft | 6 | Rotor bearing |
| 7 | Yaw drives | 8 | Gear oil cooler |
| 9 | Rotor brake | 10 | Coupling |
| 11 | Generator | 12 | Coolant pump |
| 13 | Hatch for electric chain hoist | 14 | Transformer box |

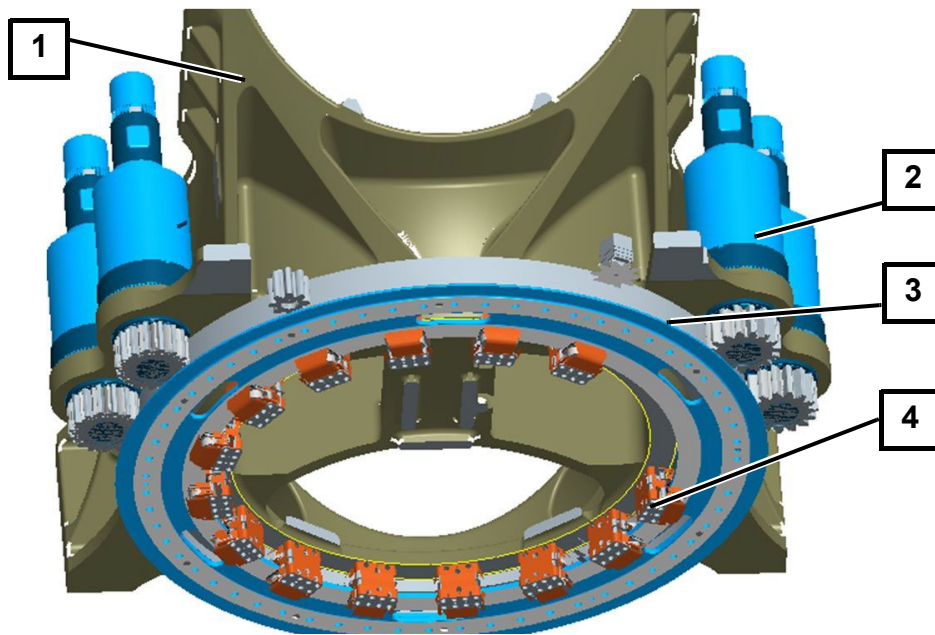

Fig. 5 Components of the yaw system

- | | | | |
|---|---------------|---|----------------|
| 1 | Machine frame | 2 | Yaw drives |
| 3 | Yaw bearing | 4 | Brake calipers |

The **hydraulic unit** provides the oil pressure required for the operation of the rotor brake and the yaw brakes.

1.4 Auxiliary systems

Rotor bearing, generator bearing, gearing of the pitch bearings and gearing of the yaw bearing are each equipped with an **automatic lubrication system**. An automatic race lubrication of the pitch bearings can be offered as an option.

The switch cabinets in the nacelle and the tower base of the wind turbine are in part equipped with **air conditioning units**.

Gearbox, generator, hydraulic unit and all switch cabinets are equipped with **heaters**.

An **electric chain hoist** is installed in the nacelle which is used for lifting tools, components and other work materials from the ground into the nacelle. An **over-head crane crossbeam including push travel trolley** together with a manual chain hoist is used to move material within the nacelle. The manual chain hoist is not included in the standard scope of delivery of the WT, but can be offered as an option.

Various options of additional equipment are available for the wind turbine.

Cooling system

Gearbox and generator are cooled by a coupled oil/water circulation. At startup the lightly heated gear oil is directly fed back into the gearbox via a thermal bypass and only directed into the plate-type heat exchanger after reaching operating temperature.

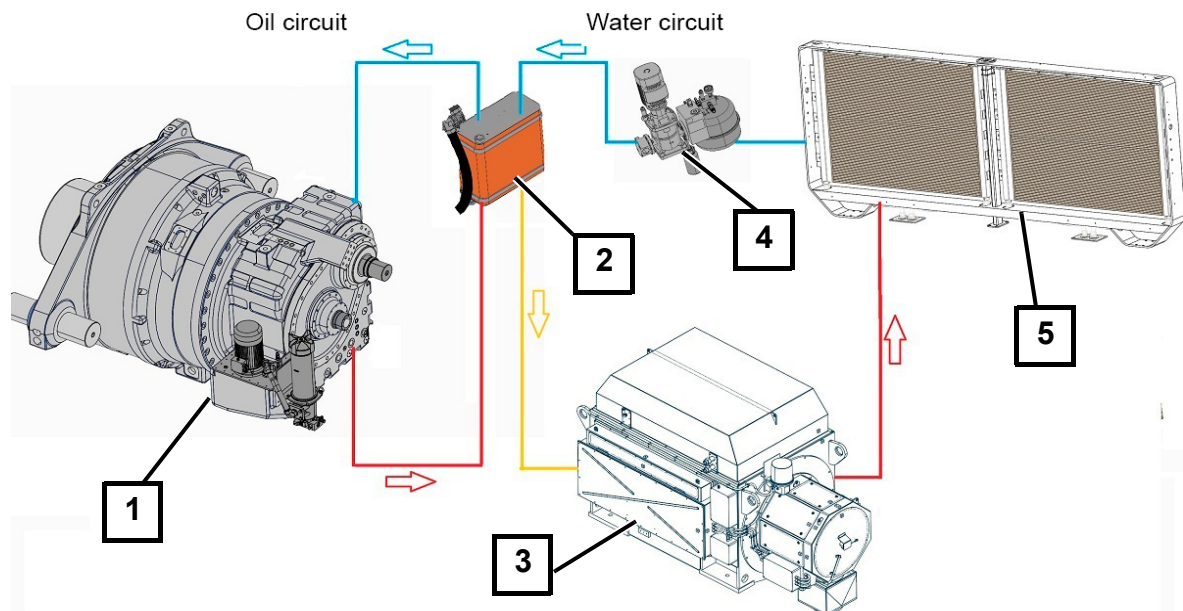

Fig. 6 Schematic diagram of gearbox cooling and generator cooling

- | | |
|---------------------------|-------------------------------|
| 1 – Gearbox with oil pump | 2 – Plate-type heat exchanger |
| 3 – Generator | 4 – Water pump |
| 5 – Passive coolers | |

The converter in the tower base is cooled by a water/glycol mixture. A pump conveys the mixture through main converter and heat exchanger. This is equipped with a two-stage blower that is controlled independently from the water temperature.

2. Functional principle

The WT operates automatically. A programmable logic controller (PLC) continuously monitors the operating parameters using various sensors, compares the actual values with the corresponding setpoints and issues the required control signals to the WT components. The operating parameters are specified by Nordex and are adapted to the individual location.

When there is no wind the WT remains in idle mode. Only various auxiliary systems are operational or activated as required: e.g., heaters, gear lubrication or PLC, which monitors the data from the wind measuring system. All other systems are switched off and do not use any energy. The rotor idles. When the cut-in wind speed is reached, the WT changes to the “ready for operation” condition. Now all systems are tested, the nacelle turns into the wind and the rotor blades turn into the wind. When a certain speed is reached, the generator is connected to the grid and the WT produces energy.

At low wind speeds the WT operates at part load. During this the rotor blades remain fully turned into the wind (pitch angle 0°). The power produced by the WT depends on the wind speed.

When the nominal wind speed is reached, the WT switches over to the nominal load range. If the wind speed continues to increase, the speed control changes the rotor blade angle so that the rotor speed and thus the power output of the WT remain constant.

The yaw system ensures that the nacelle is always optimally aligned to the wind. To this end, two separate wind measuring systems located at the height of the hub measure the wind direction. Only one wind measuring system is used for the control system, while the second system monitors the first and takes over in case the first system fails. If the wind direction measured deviates too much from the nacelle alignment, the nacelle is yawed into the wind.

The wind energy absorbed from the rotor is converted into electrical energy using a doubly-fed induction machine with slip ring rotor. Its stator is directly connected to the MV transformer, and its rotor via a specially controlled frequency converter. This offers a significant advantage enabling the generator to be operated in a defined speed range near its synchronous speed.

Safety systems

Nordex wind turbines are equipped with extensive equipment and accessories to provide for personal and turbine safety and ensure continuous operation. The entire turbine is designed in accordance with the Machinery Directive 2006/42/EC and certified as per IEC 61400. For details on the safety devices refer to the current safety manual.

If certain parameters concerning turbine safety are exceeded, the WT will cut out immediately and is put into a safe state. Depending on the cut-out cause, different brake programs are triggered. In event of external causes, such as excessive wind speeds or below operating temperatures, the wind turbine is gently braked by means of rotor blade adjustment.

Lightning protection/surge protection and electromagnetic compatibility (EMC)

The lightning/surge protection of the wind turbine is based on the EMC-compliant lightning protection zone concept, which comprises the implementation of internal and external lightning/surge protection measures under consideration of the standard IEC 61400-24.

The wind turbine falls into lightning protection level I. All components of the internal and external lightning/surge protection are designed in accordance with lightning protection level I.

The wind turbine with the electrical equipment, consumers, the measurement, control, protection, information and telecommunication technology meets the EMC requirements according to IEC 61400-1, item 10.11.

Low-voltage grid types

The **660 V low voltage network** as an IT network configuration and three phase rotary current network is insulated against ground and is the primary low voltage energy system of the wind turbine. The bodies of the electrical equipment and measuring instruments of this network are grounded directly or by means of separate protective bonding conductors. As a further protection measure for personal and turbine protection in the 660 V IT network a central insulation monitor has been installed.

The **400 V/230 V low-voltage network** has its neutral point grounded directly at the supplying network transformers as TN system and three-phase system. The equipment grounding conductor PE and the neutral conductor are available separately. The bodies of electrical equipment and consumers, including the additional protective equipotential bonding, are connected directly, through protective earthing conductor connections, straight to the neutral points of the supply grid transformers. The 400 V/230 V low voltage network is the auxiliary low voltage system of the wind turbine.

Auxiliary power of the wind turbine

The auxiliary low voltage required by the wind turbine in stand-by mode and feed-in mode is requested by the following consumers:

- Wind turbine control including main converter control
- 400 V/230 V auxiliary power of the main converter
- 230 V AC UPS supply including 24 V DC supply
- Yaw system
- Pitch system
- Hydraulic unit
- Auxiliary drives such as pumps, fans and lubrication units
- Heaters, AC units, lighting
- Auxiliary systems such as service lift, obstacle lights
- Optional systems

Based on measurements, simulations and existing operating experience, a coincidence factor of 0.6 can be estimated for the installed low voltage auxiliary power for the worst load case of the auxiliary low voltage system as well as the feed-in operation mode of the WT. In the worst load case as well as in stand-by mode of the WT, a coincidence factor of 0.2 is estimated. In addition, measurements and simulations show that the average power factor ($\cos \phi$) at the supply points of the auxiliary low voltage system does not permanently fall below approx. 0.97 in any WT operating point/load case.

Long-term measurements show that the average base load (average active power) of the auxiliary low voltage system during WT feed-in operation mode is approx. 15 kW, based on one year.

For locations with an average annual speed of 6.5 m/s approx. 10,000 kWh auxiliary consumption arise, however, this value is greatly dependent on location. Auxiliary consumption is defined as the energy consumption of the WT from the grid for a period during which the WT does not supply current to the grid.

3. Technical data

Design	
Design temperature	Standard -20 °C to +45 °C CCV: -40 °C to +45 °C
Operating temperature range	-20 °C to +40 °C [*]
Operating temperature range CCV	-30 °C to +40 °C [*]
Stop	Standard: -20 °C, restart at -18 °C CCV: -30 °C, restart at -28 °C
Max. height above MSL	2000 m ^{**}
Certificate	in accordance with IEC 61400-1 and DIBt
Type	3-blade rotor with horizontal axis Up-wind turbine
Output control	Active single blade adjustment
Rated power ^{*/**}	3000 kW / 3600 kW Power mode: 3675 kW / 3780 kW ^{***}
Rated power starting at wind speeds of (at air density of 1.225 kg/m ³)	approx. 13.0 m/s
Operating speed range of the rotor	7.9...14.1 min ⁻¹
Nominal speed	12.6 min ⁻¹
Cut-in wind speed	3.0 m/s
Cut-out wind speed	25 m/s
Cut-back-in wind speed	24.5 m/s
Calculated service life	At least 20 years

* Rated power is reached up to defined temperature ranges. Limited project-specific operating ranges are possible and must be agreed to with Nordex.

** At installation altitudes above 1000 m, the rated power is reached up to defined temperature ranges.

*** 3780 kW only approved on a country-specific basis for France and Belgium.

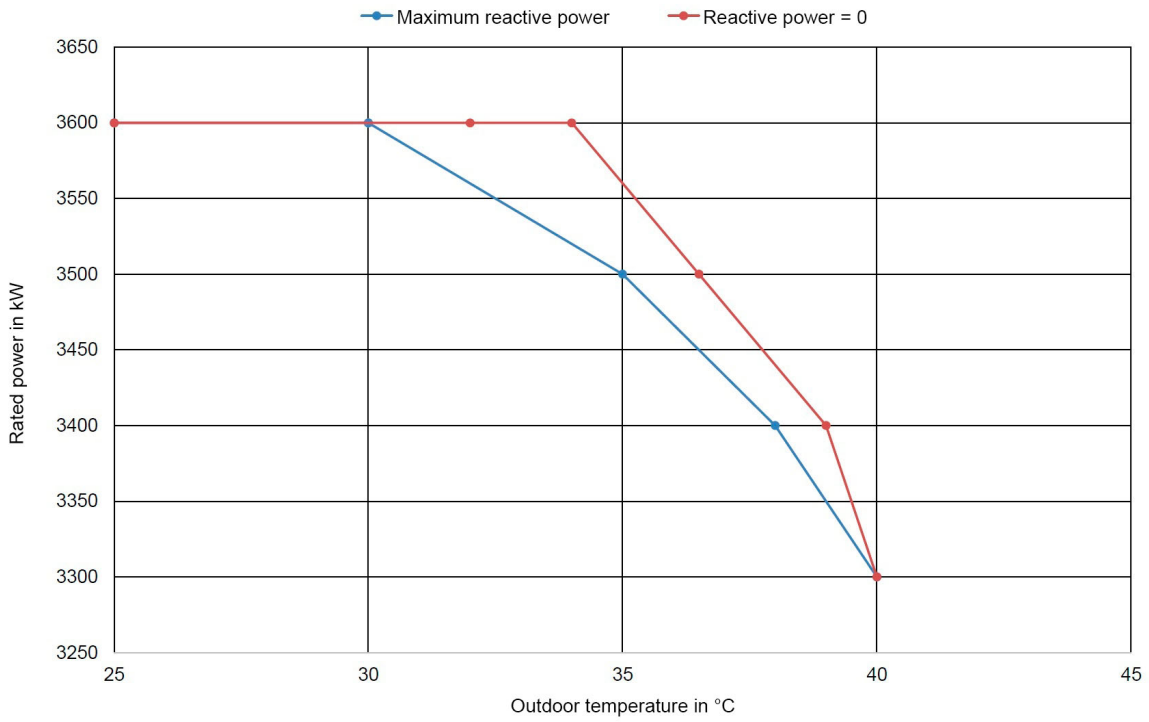

Fig. 7 Power adjustment dependent on reactive power and temperature (up to an elevation of ≤1000 m above sea level)

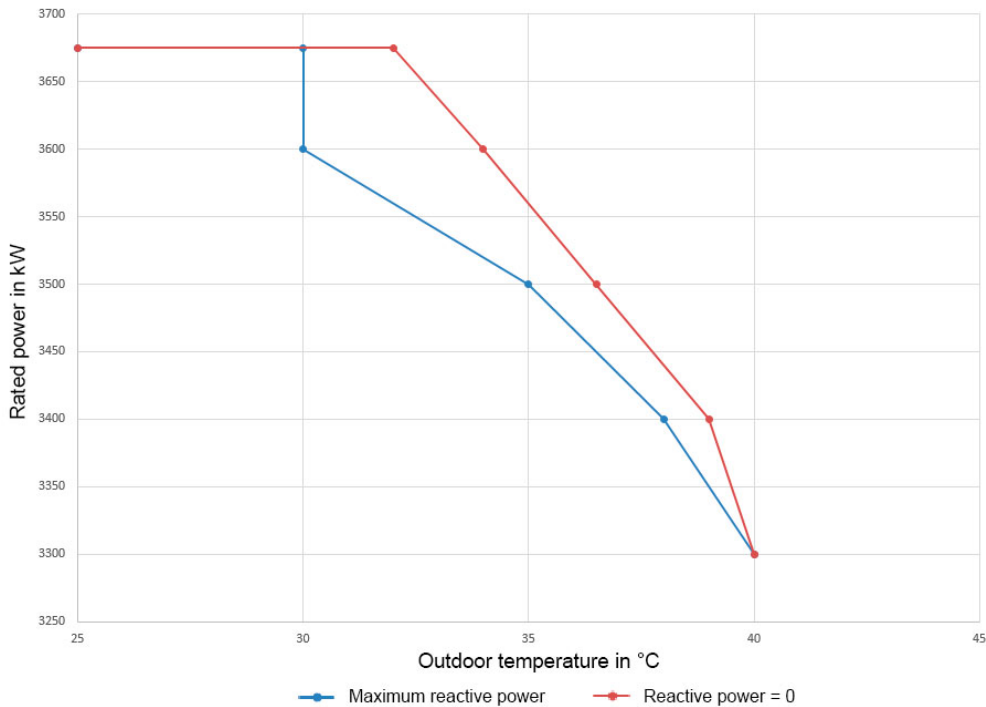

Fig. 8 Power adjustment N117/3675 dependent on reactive power and temperature (up to an elevation of ≤1000 m above sea level)

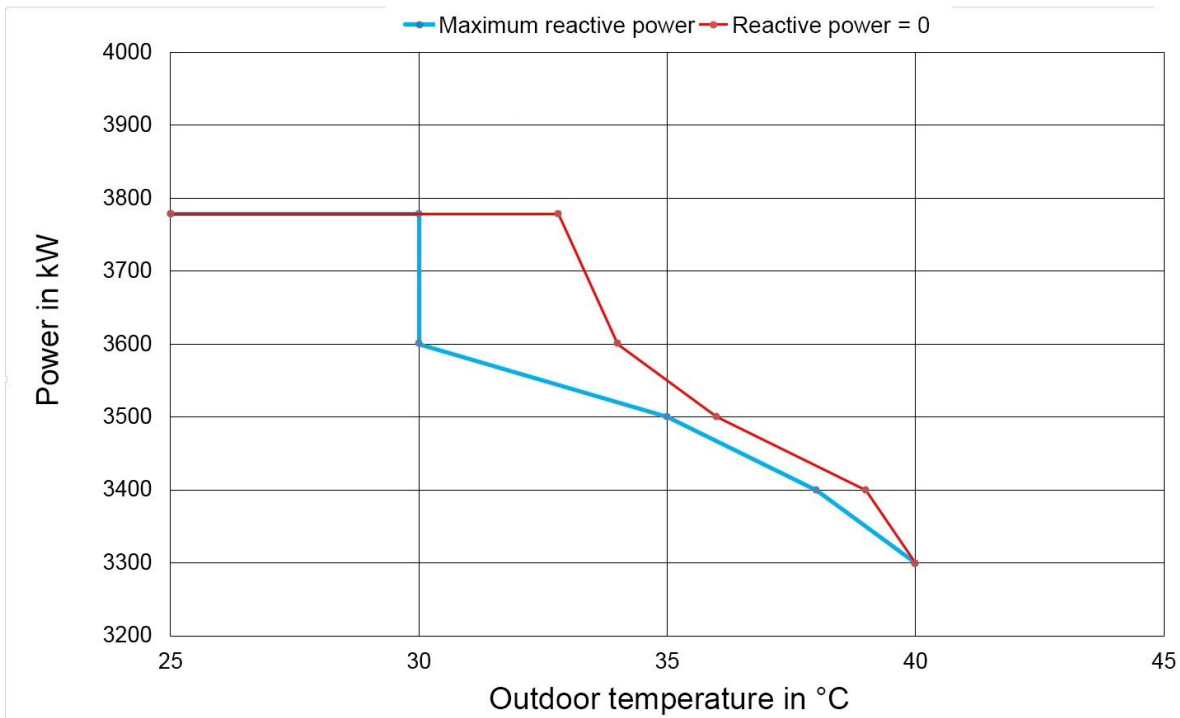

Fig. 9 Power adjustment N117/3780 dependent on reactive power and temperature (up to an elevation of ≤ 1000 m above sea level)

Towers	TS76	TS84	TS91	TS99	TS106	TS106-01	TS120	TS134
Hub height	76 m	84 m	91 m	99 m	106 m	106 m	120 m	134 m
Wind class	IEC S	IEC S	DIBt 3 / IEC IIA	IEC S	DIBt 3 / IEC IIA	IEC S	DIBt 3 / IEC IIA	DIBt 2S / IEC IIB
Quantity Tower sections	3	3	3	4	4	4	5	6

Rotor	
Rotor diameter	116.8 m
Swept area	10715 m ²
Rated power/area	336 W/m ²
Rotor shaft inclination angle	5°
Blade cone angle	3.5

Rotor blade	
Material	glass-fiber reinforced plastics and carbon-fiber reinforced plastic
Total length	57.3 m
Total weight per blade	approx. 10.6 t

Rotor shaft/rotor bearing	
Type	Forged hollow shaft
Material	42CrMo4 or 34CrNiMo6
Bearing type	Spherical roller bearing
Lubrication	Continuous and automatic with lubricating grease
Rotor bearing housing material	EN-GJS-400-18-LT

Mechanical brake	
Type	Actively actuated disk brake
Location	On the high-speed shaft
Disk diameter	920 mm
Number of brake calipers	1
Brake pad material	Sintered metal

Gearbox	
Type	Multi-stage planetary gear + spur gear stage
Gear ratio	50 Hz: $i = 92.9$ 60 Hz: $i = 110.8$
Lubrication	Forced-feed lubrication
Oil type	VG 320
Max. oil temperature	75 °C
Oil change	Change, if required

Electrical system	
Rated power P_{nG}^*	3000 kW / 3600 kW Power mode: 3675 kW / 3780 kW ^{***}
Nominal voltage	3 × AC 660 V ±10 % (specific to grid code)
Rated current I_{nG} at S_{nG}^*	3521 A
Nominal apparent power S_{nG} at P_{nG}^*	4025 kVA
Power factor at P_{nG}	1.00 as default setting 0.899 underexcited (inductive) up to 0.899 overexcited (capacitive) possible
Frequency	50 and 60 Hz

* All values are maximum values; values may vary depending on temperature and reactive power, see fig. 7 to Fig. 9.

** 3780 kW only approved on a country-specific basis for France and Belgium.

Generator	
Degree of protection	IP 54 (slip ring box IP 23)
Nominal voltage	660 V
Frequency	50 and 60 Hz
Speed range	50 Hz: 730 to 1325 min ⁻¹ 60 Hz: 876 to 1578 min ⁻¹
Poles	6
Weight	approx. 10.6 t

Gearbox cooling and filtration	
Type	1. Cooling circuit: Oil circuit with oil/water heat exchanger and thermal bypass 2. Cooling circuit: Water/air together with generator cooling
Filters	Coarse filter 50 µm / fine filter 10 µm / ultrafine filter <5 µm
Flow rate	Stage 1: approx. 75 l/min Stage 2: approx. 150 l/min

Generator cooling	
Type	Water circuit with water/air heat exchanger
Flow rate	approx. 160 l/min
Coolant	Water/glycol-based coolant

Converter cooling	
Type	Water circuit with water/air heat exchanger and thermal bypass
Coolant	Water/glycol-based coolant

Pitch system	
Pitch bearing	Double-row four-point contact bearing
Lubrication of gearing and race	Regular lubrication with grease Optional: Automatic lubrication unit with grease
Drive	Three-phase motor incl. spring-actuated brake and multi-stage planetary gear
Emergency power supply	Gel batteries

Hydraulic system	
Hydraulic oil	VG 32
Oil quantity	approx. 25 L
Thermal protection	Integrated PT100

Yaw drive	
Motor	Asynchronous motor
Gearbox	4-stage planetary gear
Number of drives	4
Lubrication	Oil, ISO VG 150
Yaw speed	approx. 0.5°/s

Yaw brake	
1. Type	Disk brake with hydraulic brake calipers
Brake pad material	Organic
Number of brake calipers	14
2. Type	Electric spring-actuated brake on every driving motor

Nordex Energy SE & Co. KG
Langenhorner Chaussee 600
22419 Hamburg
Germany
<http://www.nordex-online.com>
info@nordex-online.com

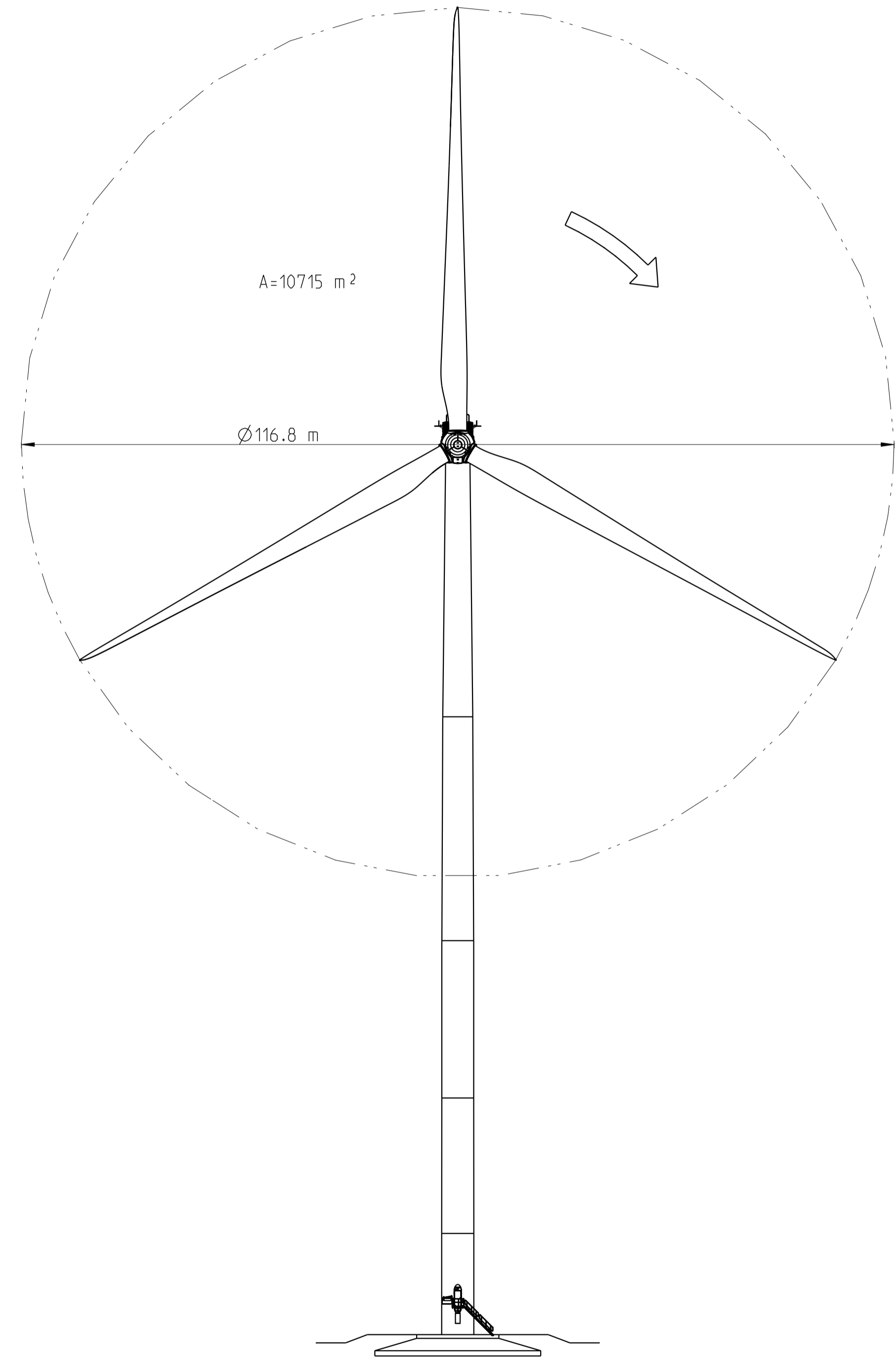
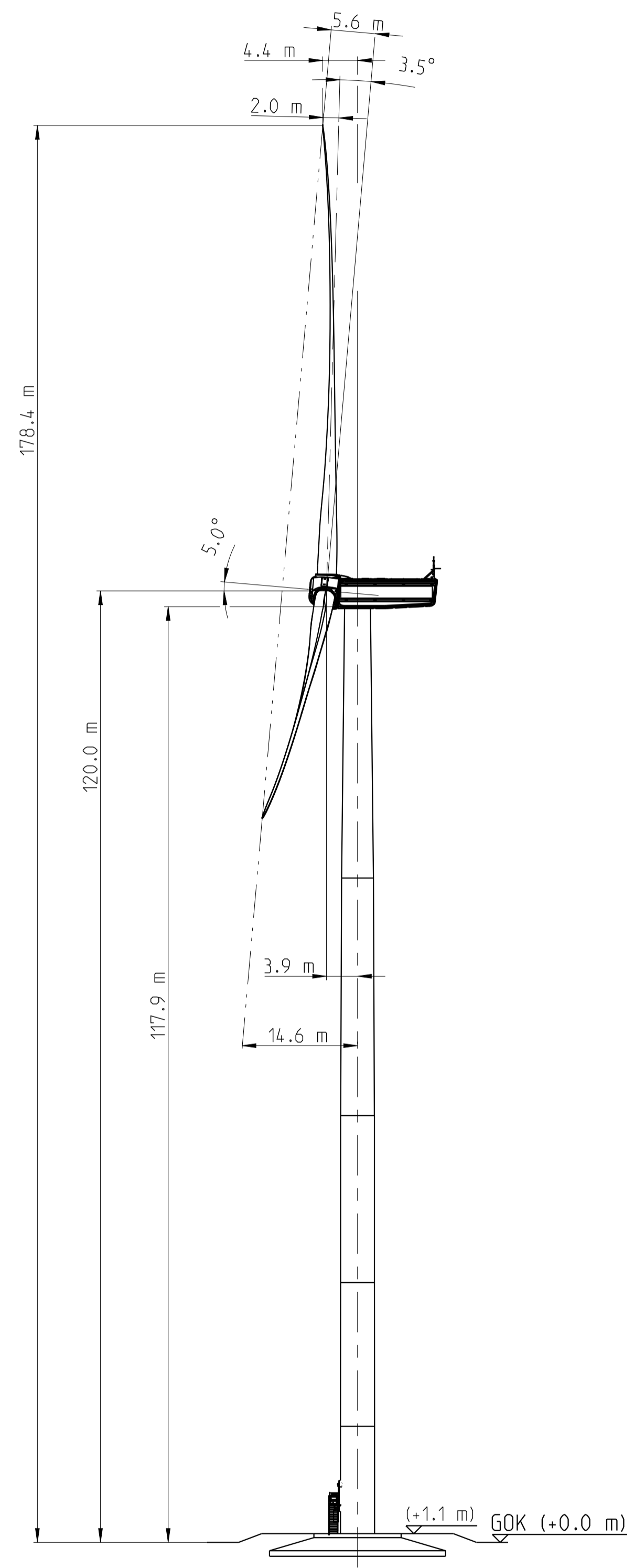

Allgemeintoleranzen/general tolerances	Dokumentart/type of document	Maßstab/scale	Gezeichnet/drawn	Gewicht/weight
-	TL01 - Übersichtszeichnung	1:500		-
Schweißnähten/welding tolerances	erstellt/created	Werkstoff/material	Geprüft/checked	ERP-Nr./no.
-	2018-06-01	-	J. Harjes	-
Gußlöcher/casting tolerances	geg. für/for	Benennung/title		
-	2020-06-10	Nordex WEA		
Werkstückkanten/edges of workpiece	freigegeben/released	Nordex WT		
-	2020-06-23	N117/3600 IEC 2a TS120 TiT		
	Schiebler Frank	Nordex WT		
		N117/3600 IEC 2a TS120 TiT		
Nordex Energy GmbH		Zeichnungsnummer/drawing number		Revision
Langenhorner Chaussee 600 22419 Hamburg Germany		00080-E0003044125		2
		Zeichnungsstatus/drawing status		Blatt/Sheet
		Released		1/2
		Format		
		A1		

Nachweislich, wie im Original, ist die Zeichnung in der angegebenen Form und Größe zu reproduzieren. Die Reproduktion ist nur für den persönlichen Gebrauch und darf nicht weiterverbreitet werden. Die Reproduktion ist nur für den persönlichen Gebrauch und darf nicht weiterverbreitet werden.

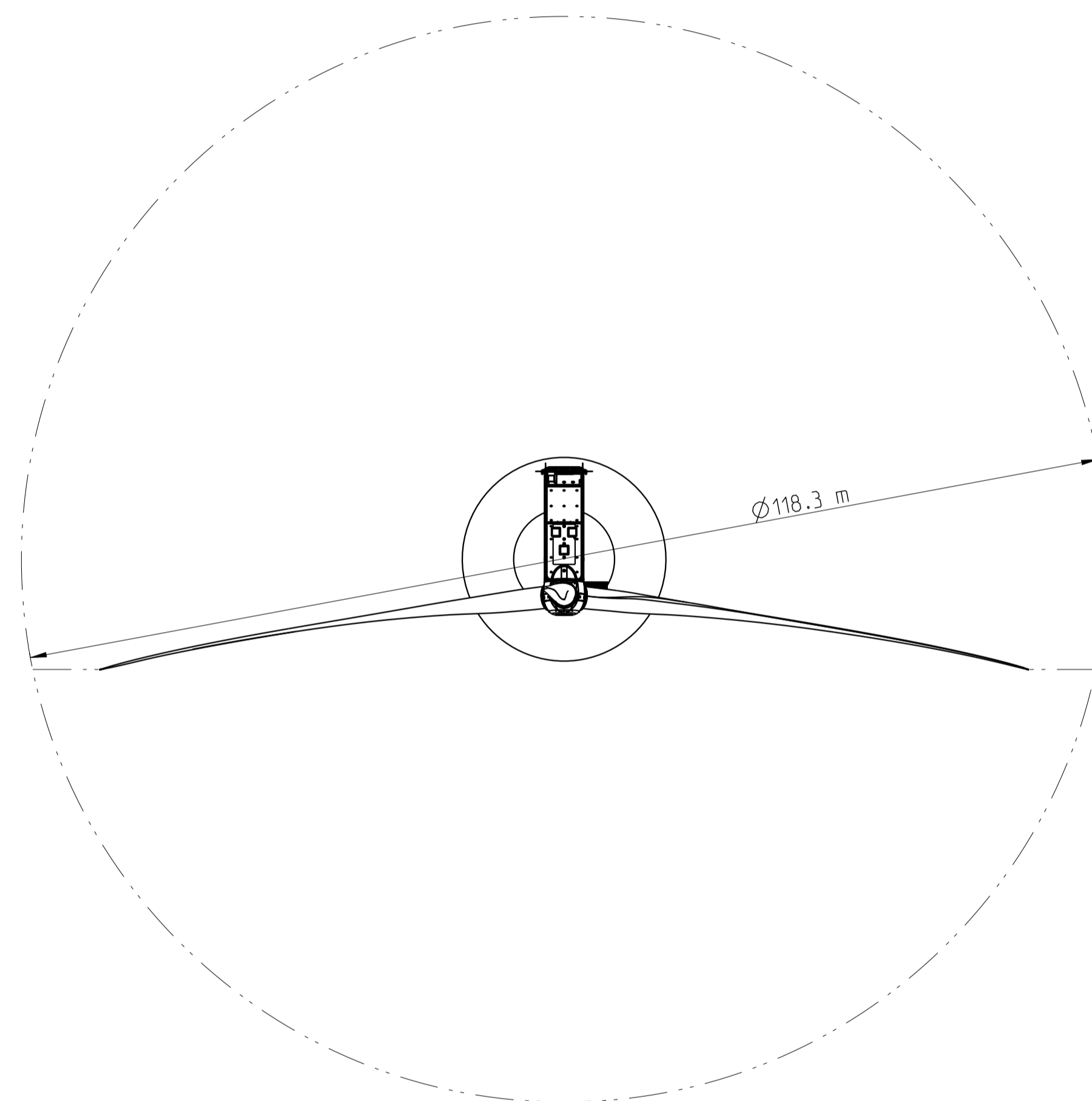
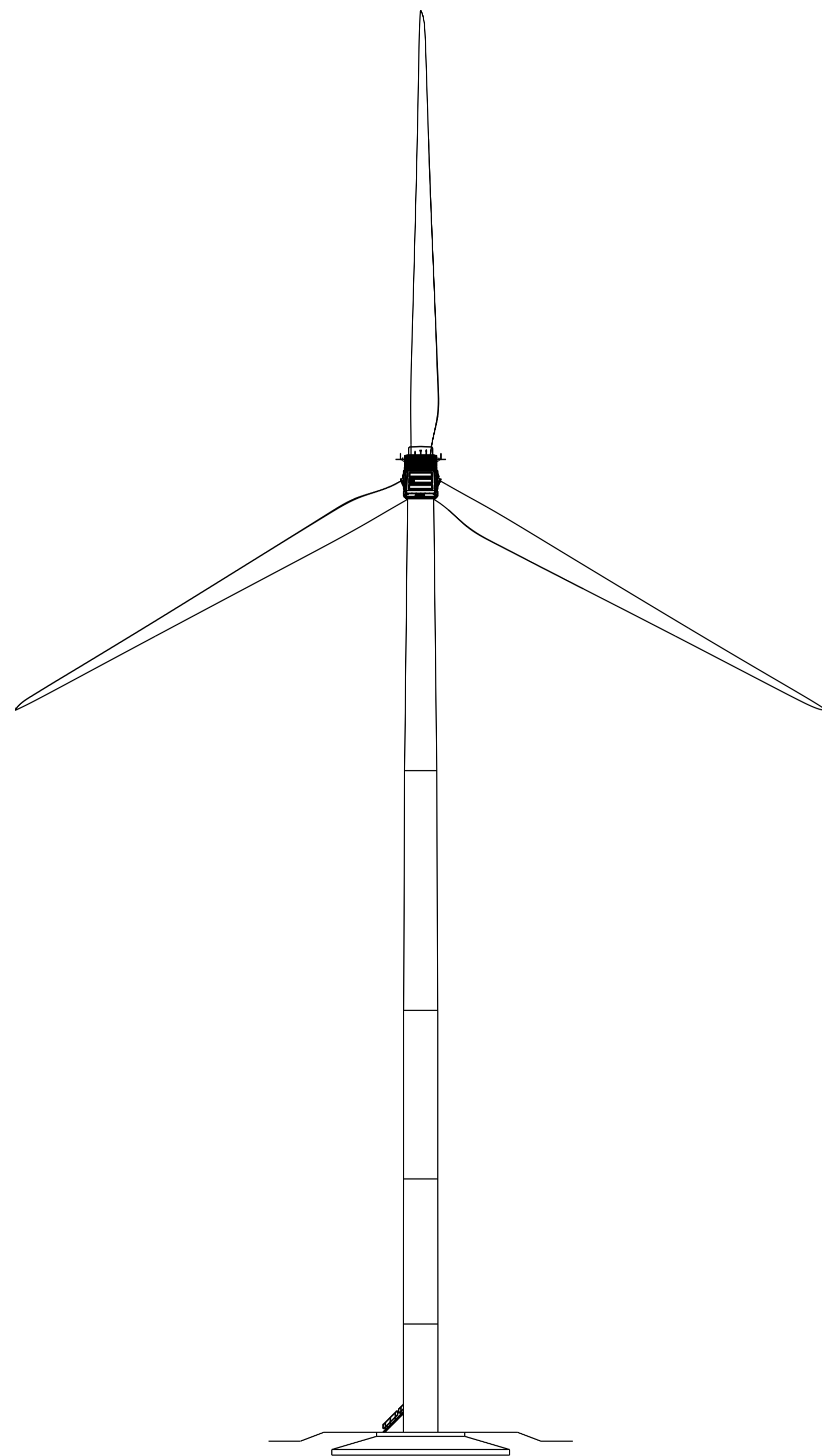

Allgemeintoleranzen/general tolerances	Dokumentart/type of document	Maßstab/scale		Gewicht/weight
Schweißnähten/welding tolerances	TL01 - Übersichtszeichnung	1:500		ERP-Nr./no.
Erstell./created	2018-06-01	Werkstoff/material	Nennung/Title Nordex WEA N117/3600 IEC 2a TS120 TiT Nordex WT N117/3600 IEC 2a TS120 TiT	
Zufließen/casting tolerances	J. Harjes			
Werkstückkanten/edges of workpiece	2020-06-10			
	Puttkammer Morten			
	freigegeben/relieved	2020-06-23		
	Schiebler Frank			
Nordex Energy GmbH Langenhorn Chaussee 600 22419 Hamburg Germany			Zeichnungsnummer/drawing number 00080-E0003044.125	Revision 2
		Zeichnungsstatus/drawing status Released	Format A1	Blatt/Sheet 2/2

Nachweislich, wie in der Zeichnung dargestellt, ist die Ausführung der Arbeit im Einklang mit den Angaben in der Zeichnung erfolgt. Die Ausführung der Arbeit ist durch die Genehmigung durch Nordex bestätigt.