

Technical description

ENERCON E-138 EP3 E3 wind energy converter

Publisher ENERCON GmbH ▪ Dreekamp 5 ▪ 26605 Aurich ▪ Germany
Phone: +49 4941 927-0 ▪ Fax: +49 4941 927-109
E-mail: info@enercon.de ▪ Internet: http://www.enercon.de
Managing Directors: Momme Janssen, Jost Backhaus, Dr. Martin Prillmann, Jörg Scholle
Local court: Aurich ▪ Company registration number: HRB 411
VAT ID no.: DE 181 977 360

Copyright notice The entire content of this document is protected by copyright and – with regard to other intellectual property rights – international laws and treaties. ENERCON GmbH holds the rights in the content of this document unless another rights holder is expressly identified or obviously recognisable.

ENERCON GmbH grants the user the right to make copies and duplicates of this document for informational purposes for its own intra-corporate use; making this document available does not grant the user any further right of use. Any other duplication, modification, dissemination, publication, circulation, surrender to third parties and/or utilisation of the contents of this document – also in part – shall require the express prior written consent of ENERCON GmbH unless any of the above is permitted by mandatory legislation.

The user is prohibited from registering any industrial property rights in the know-how reproduced in this document, or for parts thereof.

If and to the extent that ENERCON GmbH does not hold the rights in the content of this document, the user shall adhere to the relevant rights holder's terms of use.

Registered trademarks Any trademarks mentioned in this document are intellectual property of the respective registered trademark holders; the stipulations of the applicable trademark law are valid without restriction.

Reservation of right of modification ENERCON GmbH reserves the right to change, improve and expand this document and the subject matter described herein at any time without prior notice, unless contractual agreements or legal requirements provide otherwise.

Document details

Document ID	D1018637/3.2-en
Note	Original document. Source document of this translation: D1018637/3.0-de/2021-07-27

Date	Language	DCC	Plant/department
2021-08-02	en	DB	WRD Management Support GmbH / Documentation Department

Table of contents

1	Product overview	5
2	Components	7
2.1	Rotor blades	7
2.2	Nacelle	8
2.2.1	Annular generator	8
2.3	Tower	8
3	Grid management system	10
4	Safety system	12
4.1	Safety equipment	12
4.2	Sensor system	12
5	Open-loop control system	15
5.1	Yaw system	15
5.2	Pitch control	15
5.3	Start of the wind energy converter	16
5.3.1	Start lead-up	16
5.3.2	Wind measurement and nacelle alignment	16
5.3.3	Generator excitation	17
5.3.4	Power feed	17
5.4	Operating modes	18
5.4.1	Full load operation	18
5.4.2	Partial load operation	18
5.4.3	Idle mode	18
5.5	Safe stopping of the wind energy converter	19
6	Remote monitoring	20
7	Maintenance	21
8	Technical specifications of ENERCON wind energy converter – E-138 EP3 E3	22

List of abbreviations

FACTS	Flexible Alternating Current Transmission System
FT	FACTS transmission (electrical configuration with FACTS properties)
FTQ	FACTS Transmission with Q+ option (electrical configuration with extended reactive power range)
FTQS	FACTS Transmission with Q+ option and STATCOM option (electrical configuration with extended reactive power range and STATCOM option)
FTS	FACTS Transmission with STATCOM option (electrical configuration with STATCOM option)
GRP	Glass-fibre reinforced plastic
HH	Hub height
SCADA	Supervisory Control and Data Acquisition
STATCOM	Static compensator

1 Product overview



Fig. 1: Product overview

The wind energy converter generates electrical energy from the wind. Wind flowing towards the wind energy converter causes the rotor to rotate clockwise. This rotational movement is converted into electrical energy. The wind energy converter operates automatically.

The wind energy converter essentially consists of the tower, the rotating nacelle with adjustable rotor blades and electrical components for generating and conditioning the electrical energy.

Gearless

The wind energy converter drive system comprises very few rotating components. The hub and the rotor of the generator are directly interconnected without a gear to form one solid unit. This reduces the mechanical load and increases the technical service life. Maintenance and service costs are reduced and operating expenses are also kept to a minimum. Since there are no gears or other fast-rotating parts, the energy loss between rotor and generator as well as sound emissions are reduced.

Active pitch control

Active pitch control limits the rotor speed and the amount of power extracted from the wind. The maximum output of the wind energy converter can then be limited to nominal power, even at short notice. By pitching the rotor blades into the feathered position, the rotor is stopped without any load on the drive train caused by the application of a mechanical brake. The energy supply for emergency pitching of the rotor blades is located in the pitch control cabinets.

Indirect grid connection

The electrical power produced by the generator is fed via a full-scale converter into the grid. The generator is completely decoupled from the grid by the full-scale converter and the electrical properties of the generator are irrelevant to the behaviour of the wind energy converter on the grid. The grid feed system with full-scale converter ensures maximum energy yield with excellent power quality.

By decoupling the generator from the grid, it can be operated at an optimum operating point, e.g. speed, power, voltage, at any wind speed.

2 Components

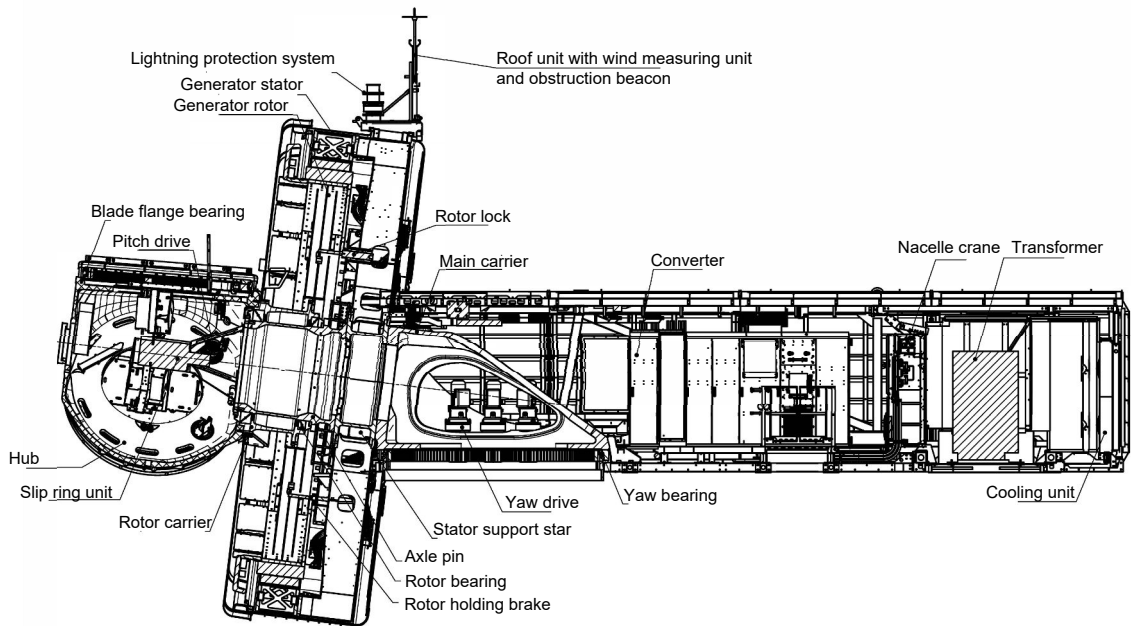

Fig. 2: Nacelle section

2.1 Rotor blades

The rotor blades are made of GRP, balsa wood and foam and are a major factor in the wind energy converter's yield and sound emissions. A rotor blade is manufactured using the half-shell construction and vacuum infusion method. The shape and profile of the rotor blades were designed with the following criteria in mind:

- High power coefficient
- Long service life
- Low sound emissions
- Low mechanical loads
- Efficient use of material

The rotor blades of a wind energy converter have been specifically designed to operate with variable pitch control and at variable speeds. A polyurethane-based surface coating protects the rotor blades from environmental influences such as UV radiation and erosion. This coating is visco-hard and highly resistant to abrasion.

Microprocessor-controlled pitch units adjust each of the 3 rotor blades independently of each other. 2 blade angle measurements each constantly monitor the set blade angle and the 3 blade angles are synchronised with each other. This enables quick and precise setting of the blade angles according to the prevailing wind conditions.

The rotor blades are equipped with a serrated profile on part of the trailing edge. This trailing edge serration reduces the turbulence on the trailing edge and thus lowers the sound emission from the wind energy converter.

2.2 Nacelle

The hub rotates around the fixed axle pin on 2 rotor bearings. Among other components, the rotor blades and the generator rotor are attached to the hub. The slip ring unit is located at the tip of the axle pin. It transmits electrical energy and data between the stationary and rotating parts of the nacelle via sliding contacts.

The stator support with its 6 supports is the load-bearing element of the fixed generator stator. The stator support star firmly connects the stator support to the main carrier. Mounted on the ends of the supports is the stator support ring, which is fitted with the aluminium windings in which electric current is induced.

The main carrier is the central load-bearing element of the nacelle. All parts of the rotor and generator are attached to it either directly or indirectly. The main carrier rotates on the tower head by means of the yaw bearing. The entire nacelle can be rotated by the yaw drives so that the rotor is always optimally aligned with the wind.

The machine house casing is made of aluminium. It is composed of multiple sections and attached to the nacelle floor by means of steel profiles.

2.2.1 Annular generator

The wind energy converters are equipped with a multi-polar, separately-excited synchronous generator (annular generator). The wind energy converter operates at variable speeds in order to optimally exploit the wind energy potential at all wind speeds. The annular generator therefore produces alternating current with fluctuating voltage, frequency and amplitude.

The windings in the stator of the annular generator form several three-phase systems that are independent of each other. These systems are actively rectified in the nacelle. The inverters then reconvert them into three-phase current whose voltage, frequency and phase position conform to the grid. The transformer in the nacelle converts the voltage generated to the level of the grid into which the current is fed. The transformer is connected to the receiving grid via the medium-voltage switchgear in the tower base.

Consequently, the annular generator is not directly connected to the receiving grid of the utility; instead, it is completely decoupled from the grid by the full-scale converter.

The generator casing is made of GRP. It is composed of multiple sections and attached to the stator support, generator stator and generator rotor by means of steel profiles.

2.3 Tower

The tower of the wind energy converter is a hybrid steel tower or hybrid tower. All towers receive the final paint coat or weather and corrosion protection at the plant, so that no further work of this kind is required after installation. As standard, the outer paintwork at the bottom of the tower has a graded colour scheme (this colour grading can be omitted as an option).

Each hybrid steel tower is a sheet steel tube that consists of a few large steel sections. Depending on the tower version, the steel sections may be single-piece or subdivided into several longitudinal elements. First, the longitudinal elements are bolted together to form steel sections at the installation site. The individual steel sections are stacked on top of each other and bolted together at the installation site. This is done for the longitudinally-divided steel sections by connection plates and for the one-piece steel sections by flange joints. They are linked to the foundation by means of a foundation basket.

The lower part of the hybrid tower is made of concrete segments and the upper part of steel sections. The concrete segments are assembled from precast elements that are stacked on top of each other at the installation site. The upper steel sections are then placed onto the concrete segments and bolted in place. The concrete segments are

prestressed vertically by means of prestressing steel tendons. The prestressing tendons run either vertically through ducts in the concrete segments or externally along the interior tower wall. They are anchored to the tower foundation.

3 Grid management system

The annular generator is coupled to the grid through the grid feed system. This system essentially consists of a modular rectifier and inverter system with a common DC link each.

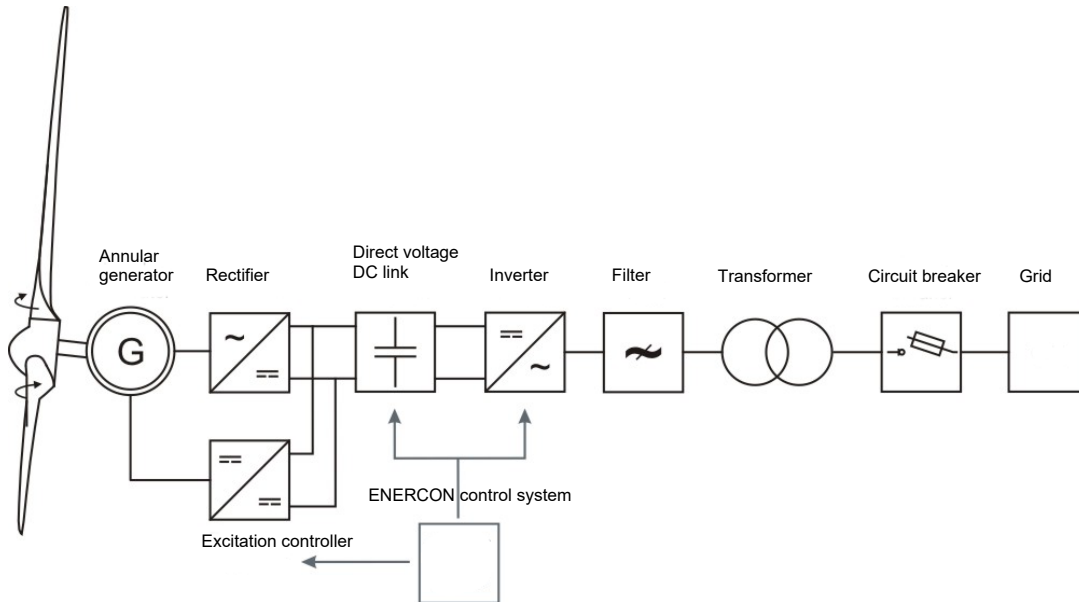

Fig. 3: Simplified electric diagram of a wind energy converter

The grid feed system, generator excitation and pitch control are all managed by the open-loop control system to achieve maximum energy yield and excellent power quality.

Optimum power transmission is achieved by decoupling the annular generator from the grid. Any sudden changes in wind speed are translated into controlled changes in the power fed into the grid. In a similar way, any disruptions from the grid have virtually no effect on the mechanics of the wind energy converter. The power fed in by the wind energy converter can be precisely regulated from 0 to 4260 kW.

In general, grid operators/owners specify the characteristics required for a certain wind energy converter or wind farm to be connected to a receiving grid. To meet different requirements, ENERCON wind energy converters are therefore available in a range of configurations.

The inverter system in the nacelle is designed according to the particular configuration of the wind energy converter. A transformer in the nacelle converts the low voltage to the desired medium voltage.

Reactive power

If necessary, a wind energy converter equipped with the standard FACTS open-loop control system can supply reactive power in order to contribute to the reactive power balance and to maintaining voltage levels in the grid. The full reactive power range is available at an output as low as 10 % of the nominal active power. The maximum reactive power range varies, depending on the configuration of the wind energy converter.

FT configuration

By default, the wind energy converter comes equipped with FACTS technology that meets the stringent requirements of specific grid codes. It is able to ride through grid faults of up to 5 seconds (undervoltage, overvoltage, automatic reclosing, etc.) and to remain connected to the grid during these faults.

If the voltage measured at the reference point exceeds a defined limit value, the wind energy converter changes from normal operation to a special fault operating mode.

Once the fault has been cleared, the wind energy converter returns to normal operation and feeds the available power into the grid. If the voltage does not return to the operating range admissible for normal operation within an adjustable time frame (5 seconds max.), the wind energy converter is disconnected from the grid.

While the system is riding through a grid fault, various fault modes using different grid feed strategies are available, including feeding in additional reactive current during the grid fault. The control strategies include different options for setting fault types.

Selection of a suitable control strategy depends on specific grid code and project requirements that must be confirmed by the particular grid operator.

FTS configuration

FT configuration with STATCOM option

Same as FT configuration; however, the STATCOM option additionally enables the wind energy converter to output and absorb reactive power regardless of whether it is generating and feeding active power into the grid. It is thus able to actively support the power grid at any time, similar to a power plant. Whether or not this configuration can be used needs to be determined on a project-by-project basis.

FTQ configuration

FT configuration with Q+ option

The FTQ configuration has all of the features of the FT configuration. In addition, it offers an extended reactive power range.

FTQS configuration

FT configuration with Q+ and STATCOM options

The FTQS configuration has all of the features of the FTQ and FTS configurations.

Frequency protection

ENERCON wind energy converters can be used in grids with a nominal frequency of 50 Hz or 60 Hz.

The range of operation of the wind energy converters is defined by a lower and upper frequency limit value. Overfrequency and underfrequency events at the reference point of the wind energy converter trigger frequency protection and cause the wind energy converter to shut down after the maximum delay time of 60 seconds has elapsed.

Power-frequency control

If temporary overfrequency occurs as a result of a grid fault, the wind energy converter can reduce its power feed dynamically to contribute to restoring the balance between the generating and transmission networks.

As a pre-emptive measure, the active power feed can be limited during normal operation. During an underfrequency event, the power reserved by this limitation is made available to stabilise the frequency. The characteristics of this control system can be adapted to various specifications in a flexible manner.

4 Safety system

The wind energy converter is equipped with a large number of safety devices, which serve to keep the wind energy converter within a constantly safe operating range. These safety devices include components for safe stopping of the wind energy converter as well as a highly developed system of sensors. The sensor system continuously records all relevant operating states of the wind energy converter and feeds the information into the ENERCON SCADA remote monitoring system.

If any safety-relevant operating parameter moves outside the permitted range, the wind energy converter then either runs at reduced power or is stopped.

4.1 Safety equipment

Emergency stop button

In wind energy converters there are emergency stop buttons on the control cabinet in the tower base, on the nacelle control cabinet and, as necessary, in the tower entrance area as well as at other locations. Actuating an emergency stop button in the tower base activates emergency pitching of the rotor blades. This brakes the rotor aerodynamically. Actuating an emergency stop button in the nacelle activates the rotor holding brake in addition to emergency pitching. This stops the rotor as quickly as possible. An emergency stop renders the wind energy converter only partially dead.

The following are still supplied with power:

- Rotor holding brake
- Beacon system components
- Lighting
- Sockets

4.2 Sensor system

A large number of sensors continuously monitor the actual status of the wind energy converter and relevant ambient parameters (e.g. rotor speed, temperature, wind speed, blade load, etc.). The open-loop control system analyses the signals and regulates the wind energy converter to optimally exploit the available energy at any given time while simultaneously maintaining operating safety.

Redundant sensors

Redundant sensors are installed to enable plausibility checks for some operating states by comparing recorded values. This applies, for example, to the measurement of the generator temperature, the wind speed or the current rotor blade angle. Defective sensors are reliably detected and can be repaired or replaced through activation of a reserve sensor. The wind energy converter is thus usually able to continue safe operation without the need for immediate service work.

Checking the sensors

Proper functioning of all sensors is either regularly checked by the wind energy converter control system itself during normal wind energy converter operation or, where this is not possible, in the course of wind energy converter maintenance work.

Speed monitoring

The wind energy converter's open-loop control system regulates the rotor speed by adjusting the blade angle in such a way that the nominal speed is not significantly exceeded, even in very strong winds. However, pitch control may not be able to react quickly enough to sudden events, such as a strong gust or a sudden reduction in generator load. If nominal speeds are exceeded by more than approx. 15 %, the open-loop control system stops the wind energy converter. After 3 minutes, the wind energy converter automatically attempts a restart. If such an event occurs more than 5 times within a 24-hour period, a defect is assumed. No further restart will then be attempted.

Exceeding the nominal speed of the rotor by more than approx. 20 % triggers emergency pitching of the rotor blades. To enable the wind energy converter to restart, the cause of the overspeed must be identified and eliminated.

The rotor speed is measured directly with a gyroscope installed in the hub. The signal is checked for plausibility with the rotor speed signal of a magnetic tape encoder.

Air gap monitoring

Microswitches distributed along the rotor circumference monitor the width of the air gap between the rotor and the stator of the annular generator. If any of the switches are triggered because the distance has dropped below the minimum distance, the wind energy converter stops and restarts automatically after a brief delay.

If the fault recurs within 24 hours, the wind energy converter remains stopped until the cause has been eliminated.

Oscillation monitoring

Oscillation monitoring detects excessive oscillation or excursion at the top of wind energy converter tower. Sensors record the acceleration of the nacelle in the hub axis direction (longitudinal oscillation) and perpendicular to this axis (transverse oscillation). The open-loop control system uses this input to continuously calculate tower excursion relative to its idle position.

Furthermore, excessive vibrations and shocks such as those that from a fault in the rectifier are detected by an integrated oscillation monitoring function. If the oscillations or excursions exceed permissible limits, the wind energy converter stops. It restarts automatically after a short delay. If impermissible vibrations are detected or if impermissible tower oscillations occur repeatedly, the wind energy converter stops and will not attempt any further restarts.

Temperature monitoring system

Some components of the wind energy converter are cooled. Temperature sensors also continuously measure components that need to be protected from high temperatures.

In the event of high temperatures, the wind energy converter's power is reduced or stopped if necessary. The wind energy converter cools down and generally restarts automatically as soon as the temperature falls below a predefined limit.

Some measuring points are equipped with additional overtemperature switches which can also stop the wind energy converter when temperatures exceed a specific limit value, and in certain situations without automatic restart after cooling down.

At low temperatures, some assemblies are heated to keep them operational, e.g. the energy storage system for the hazard beacon and the generator.

Noise monitoring inside the nacelle

There are sensors located in the rotor head of wind energy converters with nacelle-internal noise monitoring, which respond to loud knocking sounds such as might be caused by loose or defective components. If any of these sensors detect noise and there is nothing to indicate a different cause, the wind energy converter stops.

In order to rule out external causes of the noise (mainly the impact of hail during a thunderstorm), the status messages from all wind energy converters in a wind farm are compared with each other. For stand-alone wind energy converters, a noise sensor in the machine house is also used. If the sensors in multiple wind energy converters or the noise sensor in the machine house detect(s) noise simultaneously, an exterior cause is assumed. The noise sensors are deactivated briefly so that none of the wind energy converters in the wind farm have to stop.

Cable twisting monitoring

The tower cables have so much slack in the upper tower area that the nacelle can be turned left and right by 3 turns without damaging and/or overheating the tower cables. Depending on the degree of twisting and level of the wind speed, the wind energy converter open-loop control system decides when the tower cables require untwisting.

The cable twisting monitoring feature is equipped with sensors that cut the power supply to the yaw motors if the permitted adjusting range is exceeded.

5 Open-loop control system

The wind energy converter open-loop control system is based on a programmable logic controller that uses sensors to query all wind energy converter components and collect data such as wind direction and wind speed. Using this information, it adjusts the operating mode of the wind energy converter accordingly. The WEC display of the control cabinet in the tower base and in the nacelle shows the current status of the wind energy converter and any faults that may have occurred.

5.1 Yaw system

The yaw bearing with a gear rim is located on the tower head. The yaw bearing allows the nacelle to rotate, thus allowing yaw control of the nacelle.

When the difference between the wind direction and the rotor axis direction exceeds the maximum permissible value, the yaw drives are switched on and align the nacelle with the wind direction. The yaw motor open-loop control system ensures smooth starting and stopping. The open-loop control system monitors the yaw control. If it detects any irregularities, yaw control is deactivated and the wind energy converter is stopped.

5.2 Pitch control

Functional principle

The pitch unit changes the position of the rotor blades and thus the angle of attack at which the air strikes the blade profile. Changes to the blade angle change the lift at the rotor blade and therefore also the force with which the rotor turns.

In automatic mode (normal operation), the blade angle is adjusted to ensure optimal exploitation of the wind's energy while avoiding overload of the wind energy converter. Any boundary conditions, such as noise optimisation, are also observed. In addition, the pitch unit is used to decelerate the rotor aerodynamically.

If the wind energy converter achieves its nominal power and the wind speed continues to increase, the pitch unit turns the rotor blades just far enough out of the wind to keep the rotor speed and the amount of energy extracted from the wind, i.e. the energy to be converted by the generator, within or just slightly above the nominal values.

Blade angle

Special rotor blade positions (blade angle):

- A: 0° Normal position during partial load operation: maximum exploitation of available wind.
- B: $\geq 60^\circ$ Idle mode (wind energy converter does not feed any power into the grid because the wind speed is too low): Depending on the wind speed, the rotor spins at low speed or stands still (if there is no wind at all).
- C: 92° Feathered position (rotor has been stopped manually or automatically): The rotor blades do not generate any lift even in the presence of wind; the rotor stands still or moves very slowly.

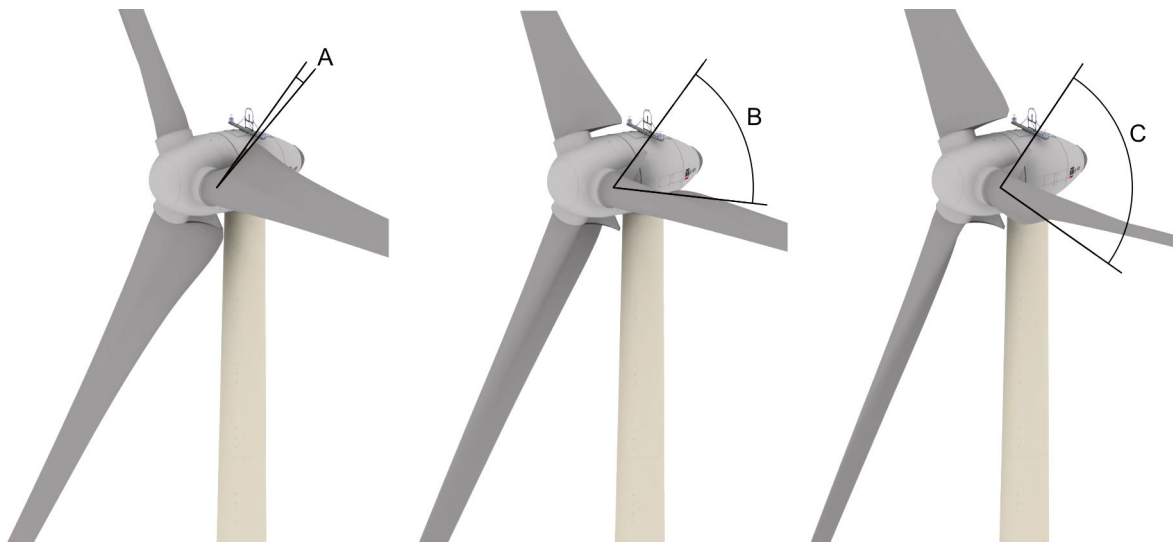

Fig. 4: Special rotor blade positions

5.3 Start of the wind energy converter

5.3.1 Start lead-up

As long as the main status is > 0 , the wind energy converter remains stopped. As soon as the main status changes to 0 , the wind energy converter is ready and the start-up process is initiated. If certain boundary conditions for start-up, e.g. charging of the emergency stop capacitors, have not been fulfilled yet, status `0:3 Start lead-up` is displayed.

During start lead-up, a wind measurement and alignment phase of 150 seconds begins for the wind energy converter.

5.3.2 Wind measurement and nacelle alignment

After completing start lead-up, status `0:2 Turbine operational` is displayed.

If the open-loop control system is in automatic mode, the mean wind speed is above 1.8 m/s and the wind direction deviation is sufficient for yawing, the wind energy converter starts alignment with the prevailing wind direction. The wind energy converter goes into idle mode 60 seconds after completing start lead-up. The rotor blades are pitched slowly into the wind while a check is performed on the emergency stop capacitors.

If the wind energy converter is equipped with rotor blade load control sensors, the rotor blades stop at an angle of 70° and adjust the rotor blade load control sensors, which may take several minutes. During this time, the status 0:5 Calibration of load control is displayed.

If the mean wind speed during the wind measurement and alignment phase of 150 seconds is above the current cut-in wind speed (approx. 2.0 m/s), the start-up process is initiated (status 0:1). Otherwise, the wind energy converter remains in idle mode (status 2:1 Lack of wind: Wind speed too low).

Power consumption

As the wind energy converter is not generating any active power at that moment, the electrical energy required for the wind energy converter's own power consumption is taken from the grid.

5.3.3 Generator excitation

Once the rotor reaches a certain speed that depends on the wind energy converter type, generator excitation is initiated. The current required for this is temporarily taken from the grid. Once the generator reaches a sufficient speed, the wind energy converter supplies itself with current. The current for self-excitation is then taken from the rectifier DC link and the energy taken from the grid is reduced to zero.

5.3.4 Power feed

As soon as the DC link voltage is sufficient and the excitation controller is no longer coupled to the grid, grid feed is initiated. When the speed increases due to sufficient wind and the power setpoint > 0 kW, line contactors on the low-voltage side are closed and the wind energy converter starts feeding power into the grid at approx. 5 rpm.

Power control regulates the stator currents and the excitation current so that the grid feed is according to the required power curve.

The power increase gradient (dP/dt) after a grid fault or a regular start-up can be defined in the open-loop control system within a certain range. For more detailed information, see the grid performance data sheet for the particular wind energy converter type.

5.4 Operating modes

After completion of the start-up process, the wind energy converter switches to automatic mode (normal operation). While in automatic mode, the wind energy converter constantly monitors wind conditions, optimises rotor speed, generator excitation and generator power, aligns the nacelle position with the wind direction and records all sensor states.

In order to optimise power generation under diverse wind conditions when in automatic mode, the wind energy converter changes between 3 operating modes, depending on the wind speed. In certain circumstances, the wind energy converter stops if provided for by its configuration (e.g. due to shadow flickering). In addition, the utility into whose grid the generated energy is being fed can be given the option to directly influence the behaviour of the wind energy converter by remote control, e.g. for temporary reduction of the grid feed.

The wind energy converter switches between the following operating modes:

- Full load operation
- Partial load operation
- Idle mode

5.4.1 Full load operation

Wind speed
 $v \geq 13.0 \text{ m/s}$

At wind speeds at and above nominal speed, the wind energy converter uses pitch control to maintain the rotor speed at the setpoint (approx. 11.1 rpm), thereby limiting power to a nominal value of 4260 kW.

5.4.2 Partial load operation

Wind speed
 $2 \text{ m/s} \leq v < 13.0 \text{ m/s}$

During partial load operation (i.e. the wind speed is between the cut-in wind speed and the nominal wind speed), the maximum possible power is extracted from the wind. The rotor speed and the power output are determined by the current wind speed. The pitch control already starts as the wind energy converter approaches full load operation so as to achieve a continuous transition.

5.4.3 Idle mode

Wind speed
 $v < 2 \text{ m/s}$

At wind speeds below 2 m/s, no current can be fed into the grid. The wind energy converter runs in idle mode, i.e. the rotor blades are turned almost completely out of the wind (blade angle $\geq 60^\circ$), and the rotor turns slowly or stops completely if there is no wind at all.

Slow movement (idling) puts less load on the rotor bearings than longer periods of complete standstill; in addition, the wind energy converter can resume power generation and grid feed more quickly as soon as the wind picks up.

5.5 Safe stopping of the wind energy converter

The wind energy converter can be stopped by manual intervention or automatically by the control system.

The causes are divided into groups by risk.

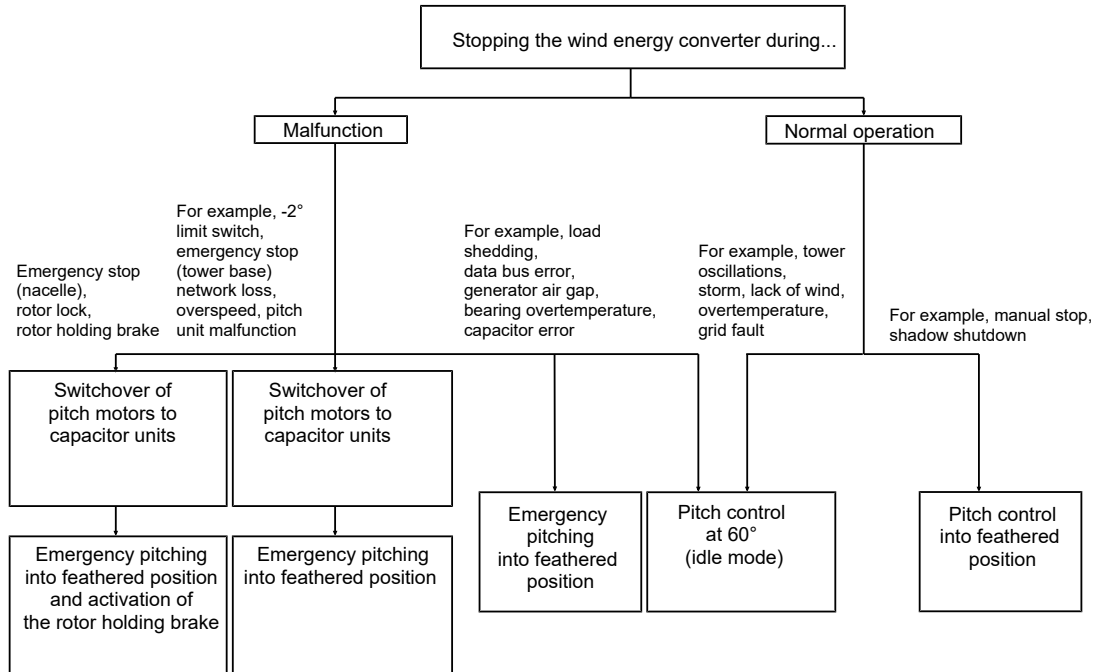

Fig. 5: Overview of wind energy converter stop

Stopping the wind energy converter by means of pitch control

In the event of a malfunction that is not safety-relevant, the wind energy converter open-loop control system pitches the rotor blades out of the wind, causing the rotor blades not to generate any lift and bringing the wind energy converter to a safe stop.

Emergency pitching

The emergency stop capacitors store the energy required for emergency pitching and are kept charged and undergo continuous testing during wind energy converter operation. For emergency pitching, each pitch motor is supplied with energy by the associated emergency stop capacitors. The rotor blades move in a controlled manner into a position in which no lift is generated; this is called the feathered position.

Since the 3 pitch units are interconnected but also operate independently of each other, if one component fails, the remaining pitch units can still function and stop the rotor.

Emergency braking

If an emergency stop button is pressed in the nacelle, or if the rotor lock is actuated while the rotor is turning, the control system initiates an emergency braking procedure.

In this case, the rotor holding brake is applied in addition to emergency pitching of the rotor blades. The rotor decelerates from nominal speed to a standstill within 10 to 15 seconds.

6 Remote monitoring

By default, all ENERCON wind energy converters are equipped with the ENERCON SCADA system that connects them to Technical Service Dispatch. Technical Service Dispatch can retrieve each wind energy converter's operating data at any time and instantly respond to any irregularities or malfunctions.

All status messages are also sent via the ENERCON SCADA system to Technical Service Dispatch, where they are permanently stored. Practical experience gained from long-term operation can then be incorporated into the further development of ENERCON wind energy converters.

Connection of the individual wind energy converters is through the ENERCON SCADA Server that is usually located in the substation or the transmission substation of a wind farm. An ENERCON SCADA Server is installed in every wind farm.

At the operator/owner's request, monitoring of the wind energy converters can be performed by a third party.

7 Maintenance

To ensure long-term safe and optimum operation of the wind energy converter, maintenance is required at regular intervals.

Wind energy converters are regularly serviced, at least once a year according to requirements.

During maintenance, all safety-relevant components and functions are checked, e.g. the pitch unit, yaw control, safety systems, lightning protection system, anchorage points and safety ladder. The bolt connections on load-bearing connections (main components) are checked. All other components are subjected to a visual inspection to check for any irregularities or damage. Any lubricants that have been used up are refilled.

The maintenance intervals and scopes may vary, depending on regional directives and standards.

8 Technical specifications of ENERCON wind energy converter – E-138 EP3 E3

General	
Manufacturer	ENERCON GmbH Dreekamp 5 26605 Aurich Germany
Type designation	E-138 EP3 E3
Nominal power	4260 kW
Design service life	25 years
Rotor diameter	138.25 m
IEC wind class (ed. 4)	IIIA (HH 160 m) SA (HH 111 m and HH 131 m)
Extreme wind speed at hub height (10-minute mean) according to IEC (ed. 4)	37.50 m/s Corresponds to a load equivalent of approx. 52.50 m/s (3-second gust)
Annual average wind speed at hub height according to IEC (ed. 4)	7.80 m/s (HH 111 m and HH 131 m) ¹ 7.50 m/s (HH 160 m)

Rotor with pitch unit	
Type	Upwind rotor with active pitch unit
Rotational direction	Clockwise
Number of rotor blades	3
Rotor blade length	67.795 m
Swept area	15011.36 m ²
Rotor blade material	GRP (glass fibre + epoxy resin)/balsa wood/foam
Lower power-feed speed	4.4 rpm
Nominal speed	11.1 rpm
Speed setpoint	11.1 rpm
Power reduction wind speed (with ENERCON storm control)	22 m/s (12-second mean) - 28 m/s (10-minute mean)
Conical angle	2.5°
Rotor axis angle	7°
Pitch unit	One independent electrical pitch unit per rotor blade with dedicated emergency power supply

¹ Although the tower configuration is designed for a reduced mean wind speed, the suitability of the site for higher mean wind speeds can be demonstrated by means of load calculations, depending on the site conditions. Taking into account a generic wind direction distribution, the design target is 8.50 m/s.

Drive train with generator	
Wind energy converter concept	Gearless, variable speed, full-scale converter
Hub	Rigid connection with generator rotor
Bearing	2 tapered roller bearings
Generator	Direct-driven, externally excited synchronous generator
Grid feed	ENERCON inverter with high clock speed and sinusoidal current
IP Code/insulation class	At least IP 23/F

Brake system	
Aerodynamic brake	Three independent pitch units with emergency power supply
Rotor holding brake	Hydraulic
Rotor lock	Latching in 10° steps

Yaw control	
Yaw system	Electromechanical yaw system

Wind energy converter control system	
Type	Microprocessor
Remote monitoring system	ENERCON SCADA system
Uninterruptible power supply (UPS)	Integrated

Tower types				
Hub height	Type	IEC Wind class ²	Turbulence category IEC ²	DIBt wind zone ³
111 m	Hybrid steel tower	S	A	WZ S
131 m	Hybrid steel tower	S	A	WZ S
160 m	Hybrid tower	III	A	WZ S

² Issue of the directive Edition 4

³ Issue of the directive 2012

Technical data sheet

General Design Conditions

ENERCON E-138 EP3 E3 / 4260 kW wind energy converter

Publisher ENERCON GmbH ▪ Dreekamp 5 ▪ 26605 Aurich ▪ Germany
Phone: +49 4941 927-0 ▪ Fax: +49 4941 927-109
E-mail: info@enercon.de ▪ Internet: http://www.enercon.de
Managing Directors: Momme Janssen, Jost Backhaus, Dr. Martin Prillmann, Jörg Scholle
Local court: Aurich ▪ Company registration number: HRB 411
VAT ID no.: DE 181 977 360

Copyright notice The entire content of this document is protected by copyright and – with regard to other intellectual property rights – international laws and treaties. ENERCON GmbH holds the rights in the content of this document unless another rights holder is expressly identified or obviously recognisable.

ENERCON GmbH grants the user the right to make copies and duplicates of this document for informational purposes for its own intra-corporate use; making this document available does not grant the user any further right of use. Any other duplication, modification, dissemination, publication, circulation, surrender to third parties and/or utilisation of the contents of this document – also in part – shall require the express prior written consent of ENERCON GmbH unless any of the above is permitted by mandatory legislation.

The user is prohibited from registering any industrial property rights in the know-how reproduced in this document, or for parts thereof.

If and to the extent that ENERCON GmbH does not hold the rights in the content of this document, the user shall adhere to the relevant rights holder's terms of use.

Registered trademarks Any trademarks mentioned in this document are intellectual property of the respective registered trademark holders; the stipulations of the applicable trademark law are valid without restriction.

Reservation of right of modification ENERCON GmbH reserves the right to change, improve and expand this document and the subject matter described herein at any time without prior notice, unless contractual agreements or legal requirements provide otherwise.

Document details

Document ID	D1025785/3.0-en
Note	Original document. Source document of this translation: D1018674/3.2-de/2021-07-22

Date	Language	DCC	Plant/department
2021-07-23	en	DA	WRD Management Support GmbH / Documentation Department

Applicable documents

The titles of the documents listed are the titles of the original language versions, with translations of these titles in brackets where applicable. The titles of superordinate standards and guidelines are indicated in the original language or as an English translation. Document IDs always refer to the original language versions. If the document ID does not contain a revision, the most recent revision of the document applies. This list contains documents concerning optional components if necessary.

Higher-level standards and guidelines

Document ID	Document
DIBt 2012	Guideline on wind energy converters, influences and stability analyses for tower and foundation, Deutsches Institut für Bautechnik (DIBt), Berlin, October 2012 version
DIN EN ISO 12944	Paints and varnishes – Corrosion protection of steel structures by protective paint systems
IEC 61400-1:2019	Wind energy generation systems – Part 1: Design Requirements

Associated documents

Document ID	Document
D0160496	Technische Beschreibung Option Cold Climate (Technical description of Cold Climate option)
D0178786	Technische Beschreibung Sturmregelung (Technical description of storm control)

Table of contents

1	Introduction	6
2	Technical specifications of wind energy converter	7
3	Wind energy converter design	8
3.1	Certified/target design requirements	8
3.2	Other site requirements	10
3.3	Application of modified design parameters	10
4	Configurations for extreme temperatures	11
4.1	Cold Climate option	11
4.2	Hot Climate option	11

List of abbreviations

HST	Hybrid steel tower
HT	Hybrid tower

1 Introduction

This document lists the main design parameters based on the official applicable standards. In addition, it lays out the main requirements for potential installation sites with respect to the structural stability of the wind energy converter.

The parameters and values listed in this document do not make any statements with respect to the general or site-specific power performance and/or noise emissions of the wind energy converter. This information is available in separate documentation.

2 Technical specifications of wind energy converter

Tab. 1: Tower versions

Type	Tower version
Hybrid steel tower	E-138 EP3 E3-HST-111-FB-C-01 E-138 EP3 E3-HST-131-FB-C-01
Hybrid tower	E-138 EP3 E3-HT-160-ES-C-01

Tab. 2: Data

Parameter	Value	Unit
Rotor diameter	138.25	m
Nominal active power	4260	kW
Cut-in wind speed	2	m/s
Nominal wind speed (simulated value, power-optimised operation)	13.0	m/s
Start of storm control ¹ (12-second mean)	22	m/s
Cut-out wind speed ² (10-minute-mean)	28	m/s
Minimum operating speed ³		
■ E-138 EP3 E3-HST-111-FB-C-01	4.4	rpm
■ E-138 EP3 E3-HST-131-FB-C-01	4.4	rpm
■ E-138 EP3 E3-HT-160-ES-C-01	4.4	rpm
Speed setpoint ⁴	11.1	rpm
Design service life	25	Years

¹ Further information concerning the ENERCON storm control feature is available in the following document D0178786 'Technische Beschreibung Sturmregelung' (Technical description of storm control).

² With activated storm control.

³ Rotational speed at which power feed starts.

⁴ Rotational speed maintained by the control system during full load operation. It is slightly greater than the nominal speed at which nominal power is first achieved. This ensures that, in the event of brief negative fluctuations of the wind speed, the rotational speed does not drop below the speed range required for achieving nominal power. With gusty winds, the rotational speed can briefly exceed the speed setpoint.

3 Wind energy converter design

3.1 Certified/target design requirements

The E-138 EP3 E3 / 4260 kW has been/will be certified for the following design requirements laid out in DIBt 2012 and IEC 61400-1:2019 (4th Edition). These design requirements must be taken into consideration for the intended installation site.

Tab. 3: Certified/target design requirements, tower-specific

Parameter	E-138 EP3 E3- HST-111- FB-C-01	E-138 EP3 E3- HST-131- FB-C-01	E-138 EP3 E3-HT-160- ES-C-01
IEC wind class (4th edition)	S	S	III
Turbulence category acc. to IEC (4th edition)	A	A	A
DIBt wind zone/terrain category	WZ S	WZ S	WZ S
50-year extreme wind speed at hub height (10-minute mean) acc. to IEC (4th edition) in m/s	37.50	37.50	37.50
Corresponds to a load equivalent of approx. (3-second gust) in m/s	52.50	52.50	52.50
50-year extreme wind speed at hub height (10-minute mean) acc. to DIBt 2012 in m/s	37.50	37.50	37.50
Annual average wind speed at hub height acc. to IEC (4th edition) in m/s	7.80 ¹	7.80 ¹	7.50
Annual average wind speed at hub height acc. to DIBt 2012 in m/s	7.80 ¹	7.80 ¹	7.71
c value of extreme turbulence model	2	2	2
Form parameter of Weibull function k	2	2	2
Wind shear	0.05 to 0.2	0.05 to 0.2	0.05 to 0.2

¹ Although the tower configuration is designed for a reduced mean wind speed, the suitability of the site for higher mean wind speeds can be demonstrated by means of load calculation depending on the site conditions. Taking into account a generic wind direction distribution, the design target is 8.50 m/s.

Tab. 4: General certified/target design requirements

Parameter	Value	
Turbulence intensity	Wind speed in at hub height in m/s	Turbulence intensity in %
	2	56.80
	4	34.40
	6	26.93
	8	23.20
	10	20.96
	12	19.47
	14	18.40
	16	17.60
	18	16.98
	20	16.48
	22	16.07
	24	15.73
	26	15.45
28	15.20	
Flow inclination	8°	
Normal temperature range	-10 °C to +40 °C	
Extreme temperature range	-20 °C to +50 °C	
Relative air humidity	≤ 95 %	
Maximum solar irradiance	1000 W/m ²	
Standard air density	1.225 kg/m ³	

The load calculations (operating and extreme loads) include a safety factor which corresponds to the load case group. As ENERCON wind energy converters are equipped with sensors that detect any rotor blade unbalance and stop the wind energy converter if necessary, unsymmetrical icing (different amounts of ice on the rotor blades) does not need to be considered.

3.2 Other site requirements

Tab. 5: Other site requirements

Parameter	Value
Distance between wind energy converters on the wind farm ¹	≥ 5 x rotor diameter in main wind direction (wind class IIA)
	≥ 3 x rotor diameter in less frequent wind directions (wind class IIA)
Maximum elevation above sea level ²	800 m
Survival temperature ³	-40 °C
Site acc. to corrosion protection class	Steel tower, outside: C4, optional C5 (acc. to DIN EN ISO 12944)
	All interior components not directly exposed to the weather: comparable to C3 'high' (acc. to DIN EN ISO 12944)

¹ These specifications are to be considered general reference values. The influence of the wake effect must be assessed for each individual project.

² Sites at higher elevations are generally also feasible; however, a project-specific assessment is required.

³ For situations with limited stress.

3.3 Application of modified design parameters

The site conditions specified in this document are general reference values. It is also possible to install and operate the wind energy converter at sites where conditions are different. However, this requires additional project-specific assessments.

The wind energy converter is equipped with an internal closed-loop control system consisting of various monitoring sensors and mechanisms (e.g. sensors for temperature, vibrations, oscillations and loads). If the closed-loop control system determines that the site conditions are outside the acceptable range, the main control system of the wind energy converter automatically takes the appropriate protective measures (e.g. transition to a power-reduced operating mode or stopping operation).

4 Configurations for extreme temperatures

4.1 Cold Climate option

For sites where temperatures drop below -20 °C on more than 9 days per year on average, ENERCON offers wind energy converters with Cold Climate option.

For further information on the Cold Climate option, refer to the ENERCON document D0160496 'Technische Beschreibung Option Cold Climate' (Technical description of Cold Climate option).

4.2 Hot Climate option

Wind energy converters with appropriately modified components are available for selected high-temperature sites upon request.

Tab. 1: Höhen, Bauart / Heights, type

Parameter	Wert / Value
Gesamthöhe ab Geländeoberkante / Total height above ground level	199,76 m
Nabenhöhe ab Geländeoberkante / Hub height above ground level	130,64 m
Nabenhöhe ab Fundamentoberkante / Hub height above foundation top edge	127,84 m
Turmhöhe ab Fundamentoberkante / Tower height above foundation top edge	125,86 m
Bauart / Type	Hybrid-Stahlurm / Hybrid steel tower

Tab. 2: Maße und Gewichte / Dimensions and weights

	Länge / Length in m	Durchmesser / Diameter in m		Gewicht / Weight in t
		Oben / Top	Unten / Bottom	
Stahlsektion / Steel section 1	28,50	4,04	4,02	55
Stahlsektion / Steel section 2	27,85	4,02	4,31	61
Stahlsektion / Steel section 3	22,84	4,32	4,37	67
Stahlsektion / Steel section 4	11,48	4,37	4,66	41
Stahlsektion / Steel section 5	11,48	4,66	4,94	43
Stahlsektion / Steel section 6	11,48	4,94	5,23	46
Stahlsektion / Steel section 7	11,48	5,23	5,51	49
T-Flansch / T-flange	0,80	5,52	5,54 6,10 ¹	17
Fundamentkorb / Foundation basket	3,24	-	5,90 ²	7

¹ Außendurchmesser Flansch / Outer diameter flange

² Außendurchmesser Ankerring / Outer diameter anchor ring

Technical specifications of ENERCON wind energy converter – E-138 EP3 E3

General	
Manufacturer	ENERCON GmbH Dreekamp 5 26605 Aurich Germany
Type designation	E-138 EP3 E3
Nominal power	4260 kW
Design service life	25 years
Rotor diameter	138.25 m
IEC wind class (ed. 4)	IIIA (HH 160 m) SA (HH 111 m and HH 131 m)
Extreme wind speed at hub height (10-minute mean) according to IEC (ed. 4)	37.50 m/s
	Corresponds to a load equivalent of approx. 52.50 m/s (3-second gust)
Annual average wind speed at hub height according to IEC (ed. 4)	7.80 m/s (HH 111 m and HH 131 m) ¹
	7.50 m/s (HH 160 m)

¹ Although the tower configuration is designed for a reduced mean wind speed, the suitability of the site for higher mean wind speeds can be demonstrated by means of load calculations, depending on the site conditions. Taking into account a generic wind direction distribution, the design target is 8.50 m/s.

Rotor with pitch unit	
Type	Upwind rotor with active pitch unit
Rotational direction	Clockwise
Number of rotor blades	3
Rotor blade length	67.795 m
Swept area	15011.36 m ²
Rotor blade material	GRP (glass fibre + epoxy resin)/balsa wood/foam
Lower power-feed speed	4.4 rpm
Nominal speed	11.1 rpm
Speed setpoint	11.1 rpm
Power reduction wind speed (with ENERCON storm control)	22 m/s (12-second mean) - 28 m/s (10-minute mean)
Conical angle	2.5°
Rotor axis angle	7°
Pitch unit	One independent electrical pitch unit per rotor blade with dedicated emergency power supply

Drive train with generator	
Wind energy converter concept	Gearless, variable speed, full-scale converter
Hub	Rigid connection with generator rotor
Bearing	2 tapered roller bearings
Generator	Direct-driven, externally excited synchronous generator
Grid feed	ENERCON inverter with high clock speed and sinusoidal current
IP Code/insulation class	At least IP 23/F

Brake system	
Aerodynamic brake	Three independent pitch units with emergency power supply
Rotor holding brake	Hydraulic
Rotor lock	Latching in 10° steps

Yaw control	
Yaw system	Electromechanical yaw system

Wind energy converter control system	
Type	Microprocessor
Remote monitoring system	ENERCON SCADA system
Uninterruptible power supply (UPS)	Integrated

Tower types				
Hub height	Type	IEC Wind class ²	Turbulence category IEC ²	DIBt wind zone ³
111 m	Hybrid steel tower	S	A	WZ S
131 m	Hybrid steel tower	S	A	WZ S
160 m	Hybrid tower	III	A	WZ S

² Issue of the directive Edition 4

³ Issue of the directive 2012

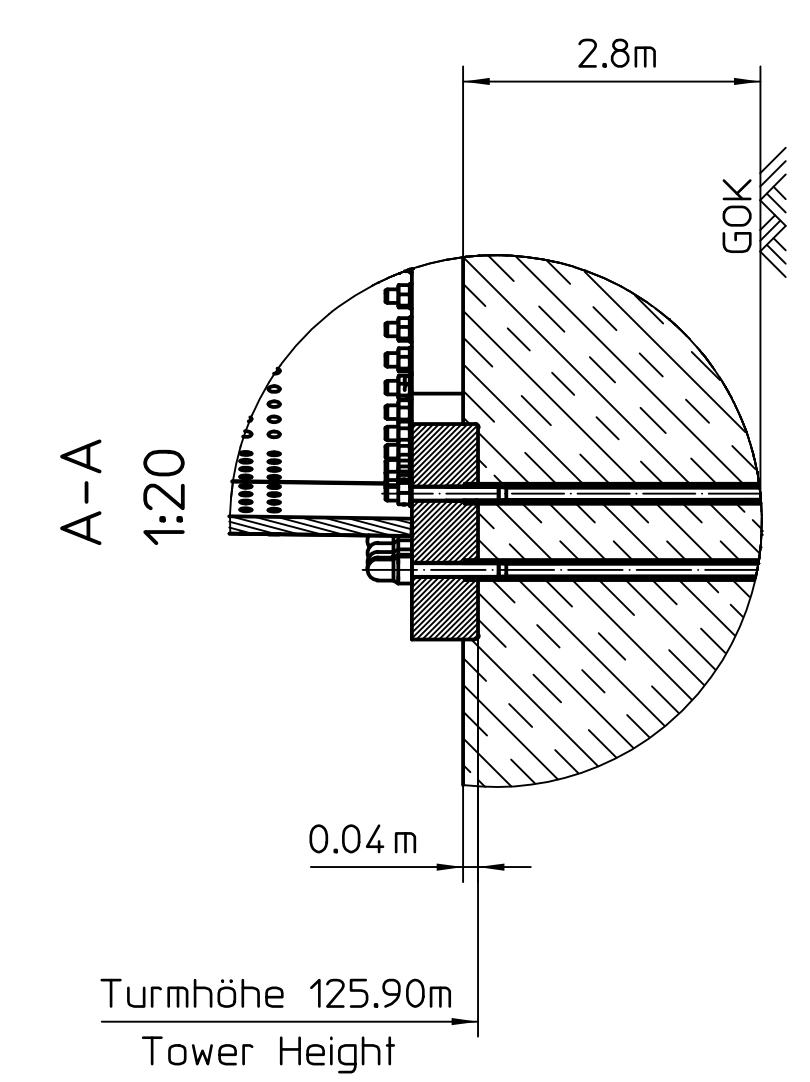
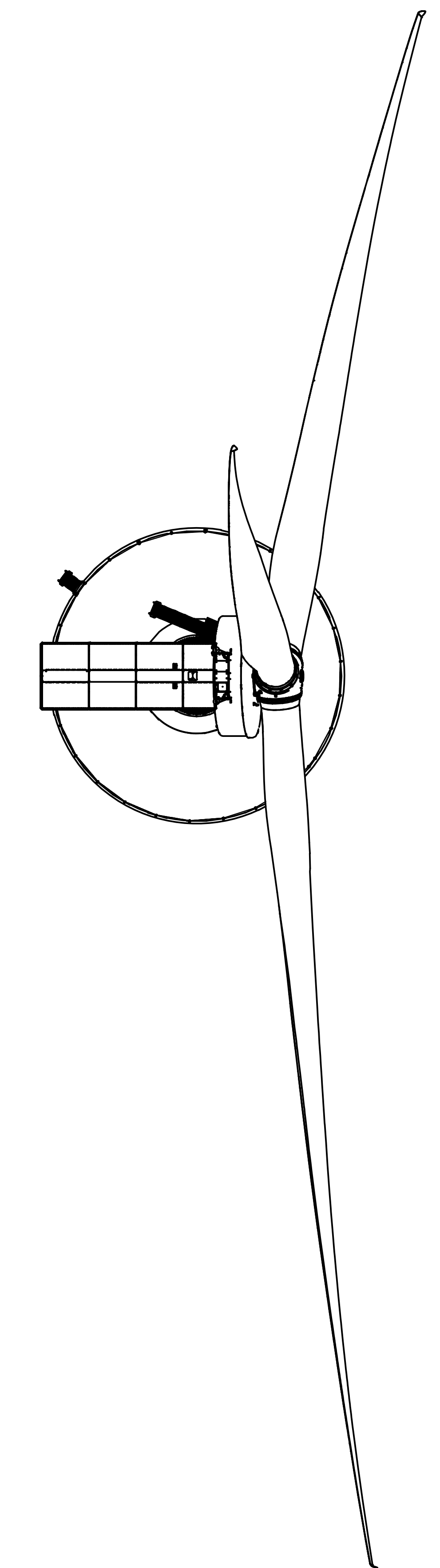
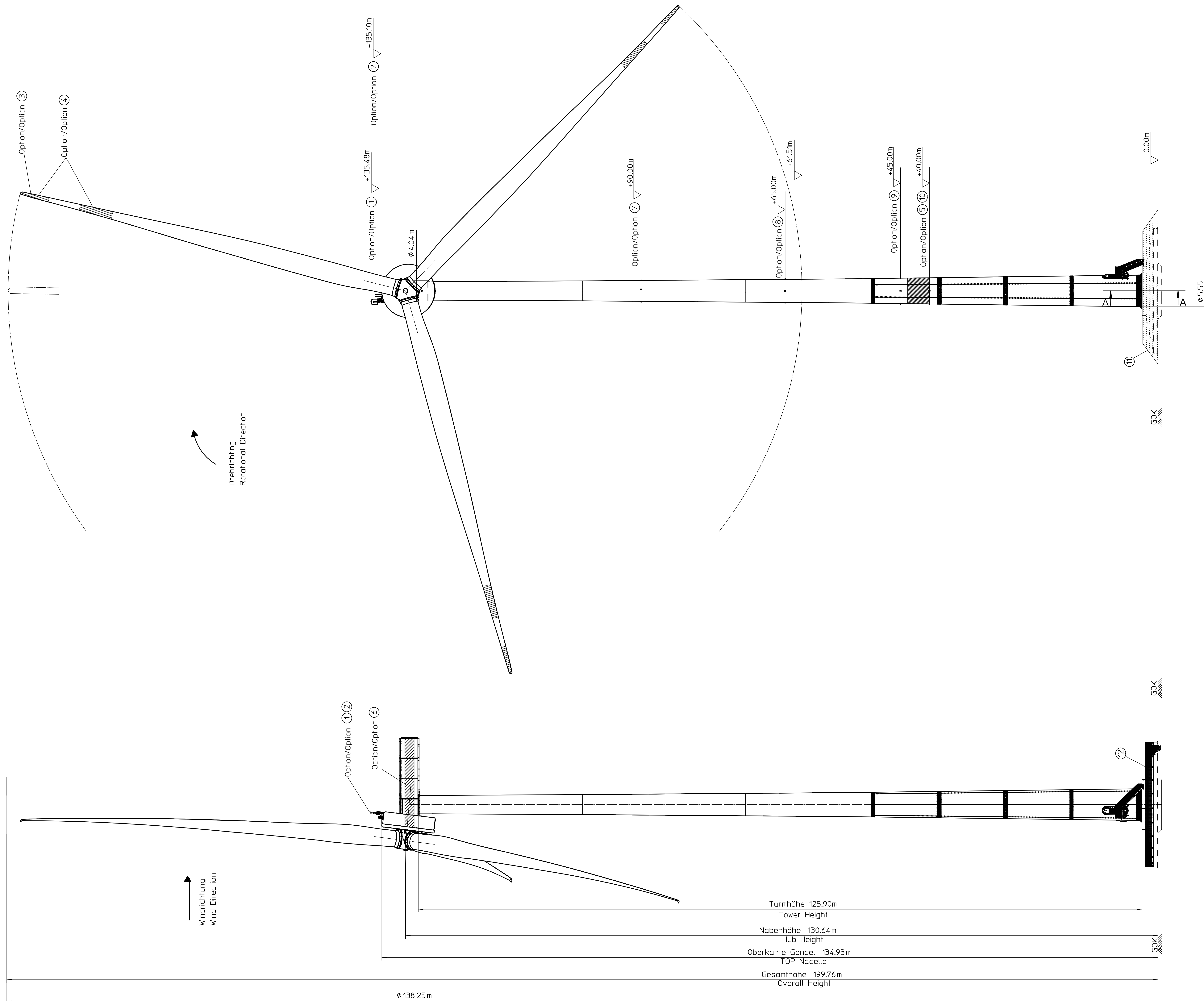

Höchste Blattposition
Highest position of blade

Windrichtung
Wind Direction

Drehrichtung
Rotational Direction

Turmhöhe 125.90m
Tower Height
Nabenhöhe 130.64m
Hub Height
Oberkante Gondel 134.93m
TOP Nacelle
Gesamthöhe 199.76m
Overall Height

Projektbezogene Angaben / Project-specific data	
Projekt / Project:	
Geländehöhe über NN / Ground elevation above sea level:	
Gesamthöhe über NN / Total elevation above sea level:	
FOK: Fundamentoberkante / Top foundation	
GOK: Geländeoberkante / Top ground	
Optionen / Options:	
① Nachtkennzeichnung / Nighttime marking: W - Rot / W - Red	
② Tageskennzeichnung / Daytime marking: weißes Blitzlicht mit Sichtweitenreduzierung white strobe lights with visibility reduction	
③ Tageskennzeichnung / Daytime marking: 6m rot (RAL 3020) / graues Rotorblatt (RAL 7038) / 6m red (RAL 3020) grey rotor blade (RAL 7038)	
④ Tageskennzeichnung / Daytime marking: rot/graurot (RAL 3020 / RAL 7038 / RAL 3020) je 6m lang / red/grey/red (RAL 3020 / RAL 7038 / RAL 3020) each 6m long	
⑤ Tageskennzeichnung / Daytime marking: 3m Farbfeld RAL 3020 / 3m colour field RAL 3020	
⑥ Tageskennzeichnung / Daytime marking: Farbfelder beidseitig an der Gondel- verkleidung RAL 3020 / Double-sided colour field on nacelle RAL 3020	
⑦ Nachtkennzeichnung / Nighttime marking: Hindernisse auf jeder Turmchse / obstruction beacon on every tower axis	
⑧ Nachtkennzeichnung / Nighttime marking: Hindernisse auf jeder Turmchse / obstruction beacon on every tower axis	
⑨ Nachtkennzeichnung / Nighttime marking: Hindernisse auf jeder Turmchse / obstruction beacon on every tower axis	
⑩ Nachtkennzeichnung / Nighttime marking: Hindernisse auf jeder Turmchse / obstruction beacon on every tower axis	
⑪ Gründung auf Geländeoberkante mit Einbindung in den Boden und Aufschüttung / Foundation on ground level with lowered sole slab and backfill	
⑫ Gründung auf Geländeoberkante mit Einbindung in den Boden und Treppe mit Geländer / Foundation on ground level with lowered sole slab and stairs with guardrail	

		Allgemeine Angaben General Information	
Name: 1250 Serie: 1250	Blatt: 1/1 Maßstab: 1:1	Datum: 25.11.2020 Zeichner: A. Albers	Projekt: WRD-Turm Blatt: EP3.00.241 - 2
2. Änderung geteilt 10/27/21 TOE ASA 1. Zeichnung 24/02/21 TOE ASA Rev. Änderung/Change Eng. No. Name		Ansichtszeichnung Hybrid-Stahlurm elevation drawing hybrid steel tower E-138 EP3 E3-HST-131-FB-C-01	

Technische Änderungen vorbehalten
Subject to technical change without prior notice